

AC 45 City

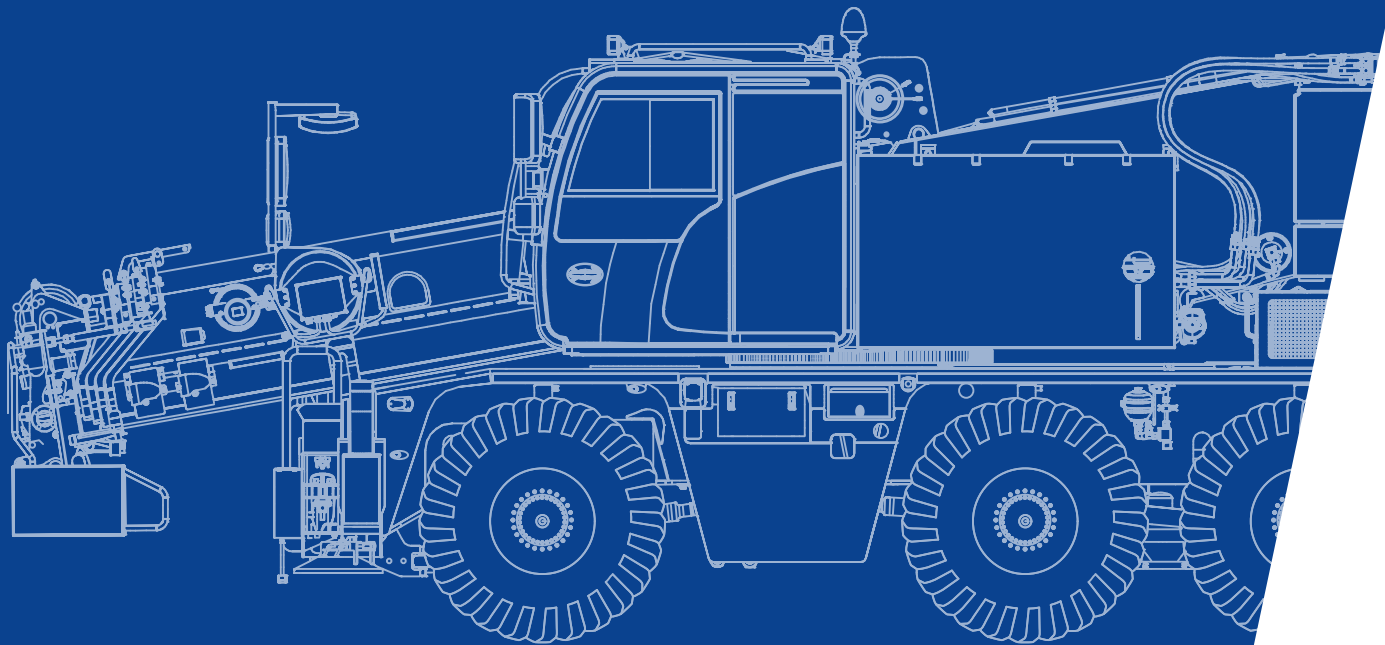

**All Terrain Crane
50 USt Capacity class**

	Page:
Dimensions.....	4
Specifications.....	5
Equipment.....	8
Counterweight.....	9

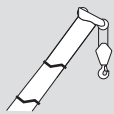

HA Main boom	10
------------------------------	----

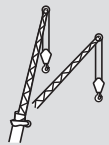

HAV Folding swing-away jib	18
--	----

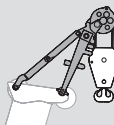

MS Runner	24
---------------------------	----

Technical description.....	42
----------------------------	----

	Counterweight		Rope diameter
	Lifting capacities on outriggers 360°		Rope length
	Radius		Hook block (capacity-sheaves-rope diameter)
	Main boom		Number of lines
	Folding swing-away jib		Possible load of hook block
	Runner		Weight of hook block
	Free on wheels		Distance head sheave axle – hook ground
	Max. axle loads		Number of sheaves in boom head
	Mechanism		Supporting force
	Tires		Length of stroke (support cylinders)
	Hook block		Payload incl. rear storage box
	Hoist		MS at carrier tail
	Travel speed		MS at main boom
	Gradeability – road		Underride guard
	Gradeability – off road		CombiBox tail
	Slewing		CombiBox tail incl. payload
	Boom telescoping		Timber storage front
	Boom elevation		Timber storage front incl. timber
	Working speeds		Hook storage
	Max. line pull		Hook storage incl. hook block

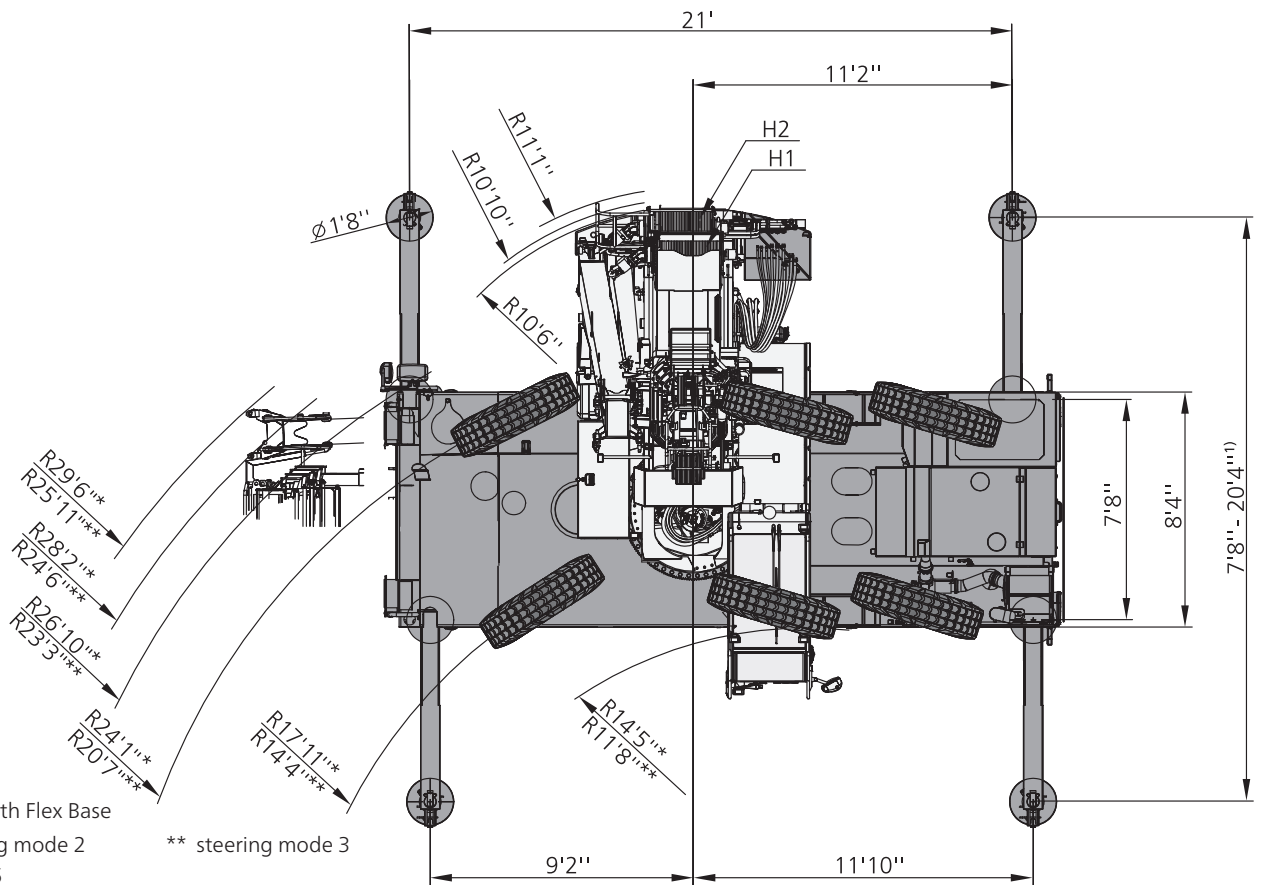
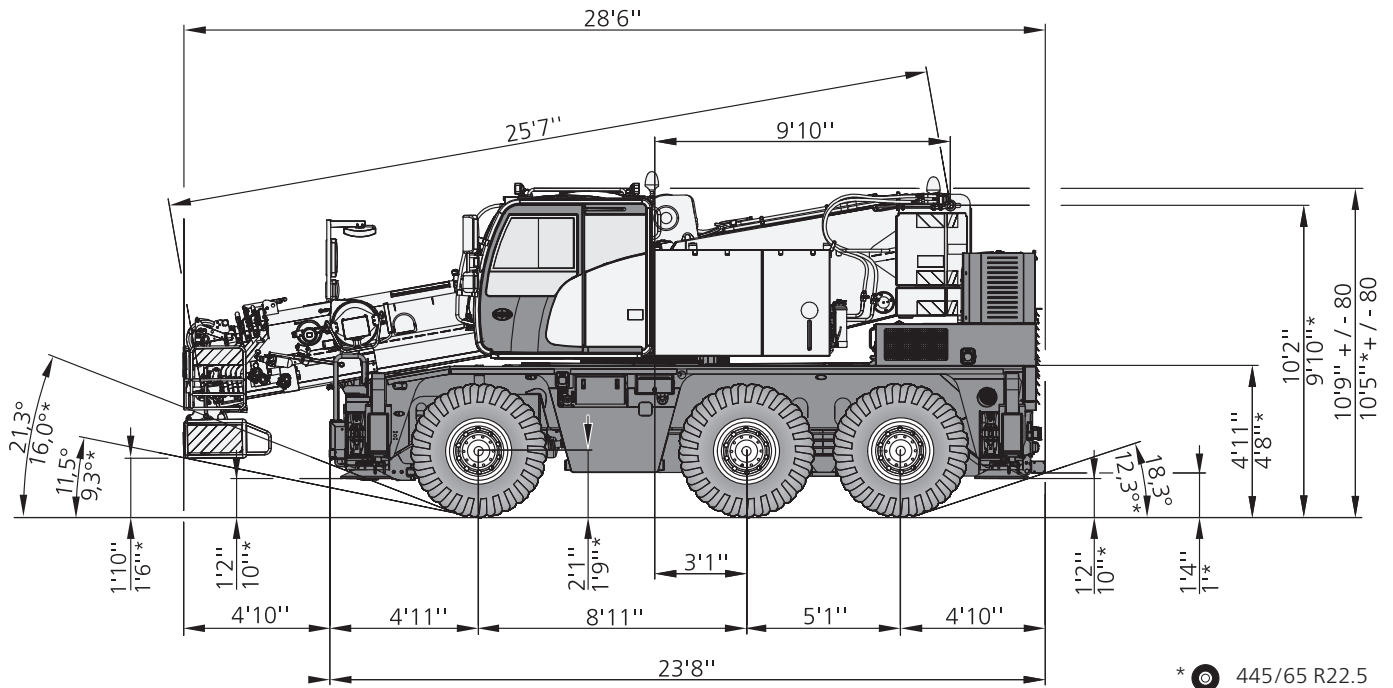

1) only with Flex Base











* steering mode 2



** steering mode 3

see page 5

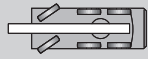
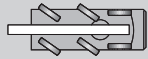
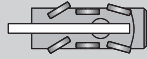
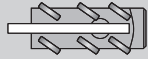

Specifications

AC 45 CITY

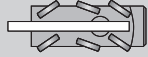

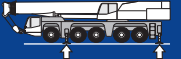

		Total								
	22,050 lb	57,300 lb	6 x 6 x 6	385/95R25	102.4 ft	-	-	-	-	-
	22,050 lb	66,100 lb	6 x 6 x 6	385/95R25	102.4 ft	32-3-16	6,400 lb	-	X	-
	26,500 lb	75,000 lb	6 x 6 x 6	385/95R25	102.4 ft	32-3-16	11,700 lb	42.7 ft	X	880 lb









	1 Highway > 28.0 mph		4* Off-wall
	2 City < 28.0 mph		5* Crab steer mode
	3* Minimum turning radius < 12.4 mph		6* Manually steered

*must be activated

	
70,560 lb	63,950 lb
19.7 ft	19.7 ft
49.7 mph ¹⁾	

¹⁾ Depending on tire type, size and country specific legislation

		
	445 / 65 R22.5 18.00 R22.5	385 / 95 R25 14.00 R25
	35 %	29 %
	> 80 %	70 %

				
1	364 ft/min	9,847 lbf	0.63 in.	459 ft
2	364 ft/min	9,847 lbf	0.63 in.	459 ft
	1,70 min ⁻¹			
	80 s (25.6 ft – 102.4 ft)			
	50 s (-10° - 77°)			

					
1	9,700	5-0-16	5	287 lb	2.6 ft
2	19,400	16-1-16	5	496 lb	3.6 ft
3	29,000	16-1-16	5	496 lb	3.6 ft
4	38,400	32-3-16	5	772 lb	4.3 ft
5	47,800	32-3-16	5	772 lb	4.3 ft
6	57,100	32-3-16	5	772 lb	4.3 ft
7	66,200	32-3-16	5	772 lb	4.3 ft
8	75,300	50-5-16	5	904 lb	6.2 ft
9	84,300	50-5-16	5	904 lb	6.2 ft
10	88,200	50-5-16	5	904 lb	6.2 ft

Weights and axle loads

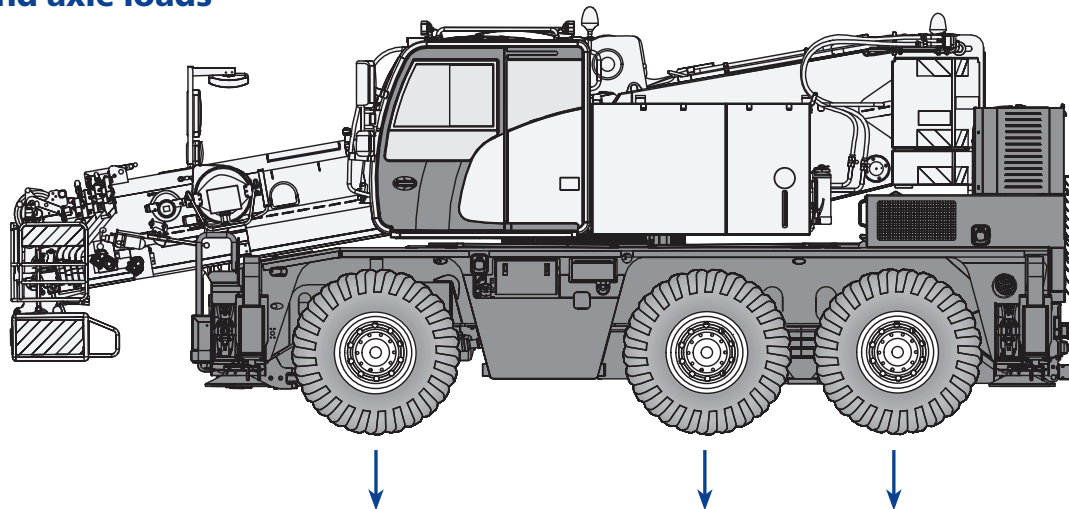









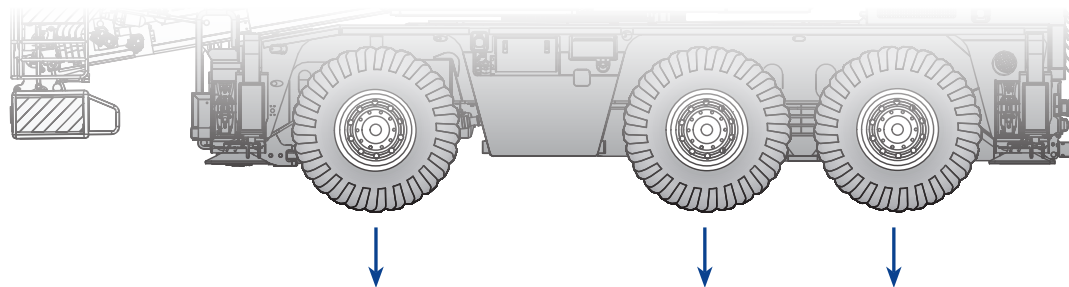

	Axle 1	Axle 2	Axle 3	Total
Basic crane				
6 x 4 x 6				
11,700 lb	19,018 lb	24,141 lb	24,223 lb	67,382 lb
Michelin 445/65 R22.5 (18.00 R22.5)				
32-3-16-D				

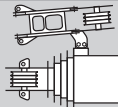
Adjust gross vehicle weight and axle loading according to component weight. All weights are $\pm 3\%$.

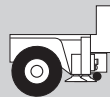
removal				
5,300 lb (c)	+ 1,738 lb	- 3,455 lb	- 3,489 lb	- 5,205 lb
2,000 lb (b)	+ 670 lb	- 1,303 lb	- 1,316 lb	- 1,949 lb
4,400 lb (a)	+ 1,390 lb	- 2,936 lb	- 2,965 lb	- 4,511 lb
32-3-16-D	- 1,218 lb	+ 222 lb	+ 224 lb	- 772 lb
substitution				
6 x 6 x 6	+ 95 lb	+ 252 lb	+ 166 lb	+ 514 lb
385/95R25 (14.00R25) Michelin	+ 390 lb	+ 390 lb	+ 390 lb	+ 1,171 lb
16-1-16-E	- 348 lb	+ 63 lb	+ 64 lb	- 220 lb
5-0-16-E	- 773 lb	+ 143 lb	+ 145 lb	- 485 lb

Weights and axle loads

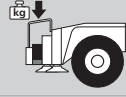
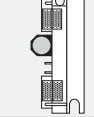

	Axle 1	Axle 2	Axle 3	Total
addition				
 42.7 ft	+ 1,205 lb	+ 252 lb	+ 255 lb	+ 1,713 lb
	- 430 lb	+ 535 lb	+ 541 lb	+ 646 lb
	+ 712 lb	- 131 lb	- 133 lb	+ 448 lb
 2	+ 390 lb	+ 447 lb	+ 443 lb	+ 1,281 lb
	- 45 lb	+ 60 lb	+ 60 lb	+ 75 lb
	- 86 lb	+ 109 lb	+ 110 lb	+ 132 lb
	- 225 lb	+ 287 lb	+ 290 lb	+ 353 lb
	+ 178 lb	- 27 lb	- 28 lb	+ 123 lb
	+ 790 lb	- 112 lb	- 113 lb	+ 565 lb
	+ 142 lb	- 22 lb	- 22 lb	+ 99 lb
 5-0-16-E	+ 411 lb	- 62 lb	- 63 lb	+ 286 lb

Equipment

AC 45 CITY

HAV

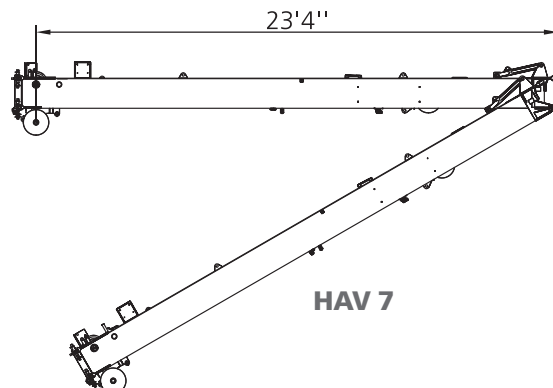
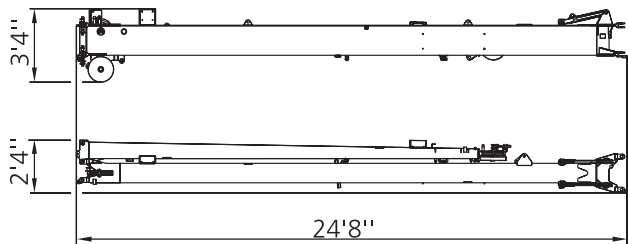

HAV 7

Weight: 1,210 lb

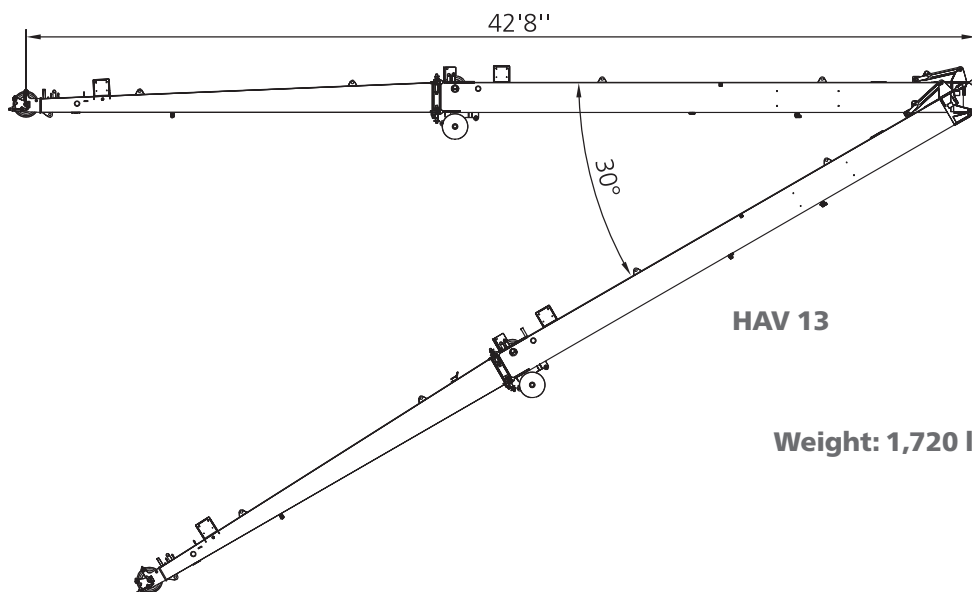

HAV 13

Weight: 1,720 lb

MS

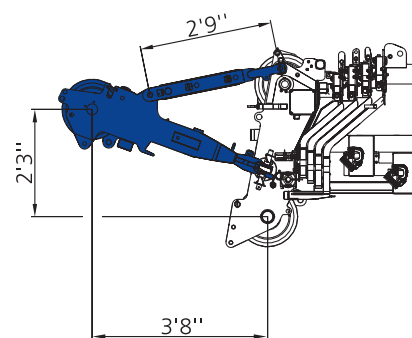
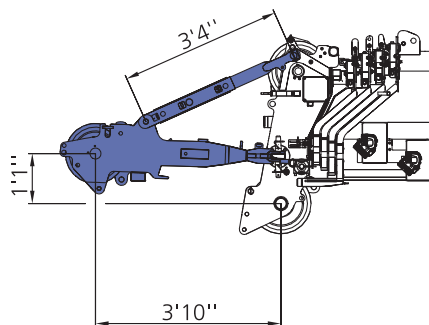
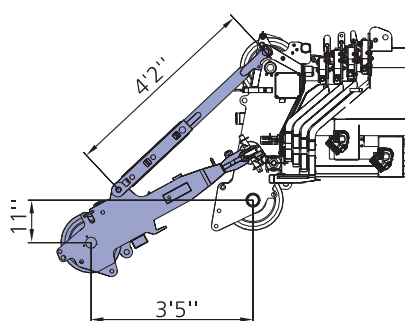

Weight: 420 lb

Counterweight

AC 45 CITY

Parts

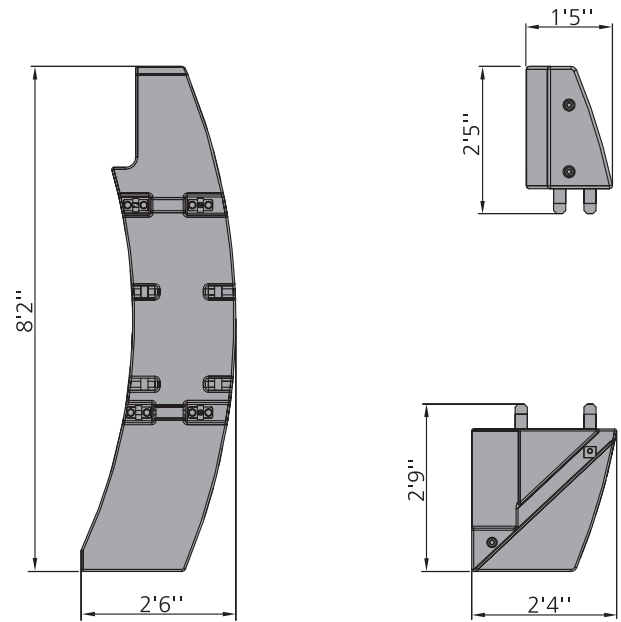
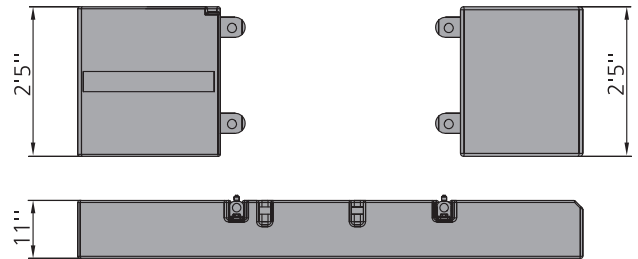
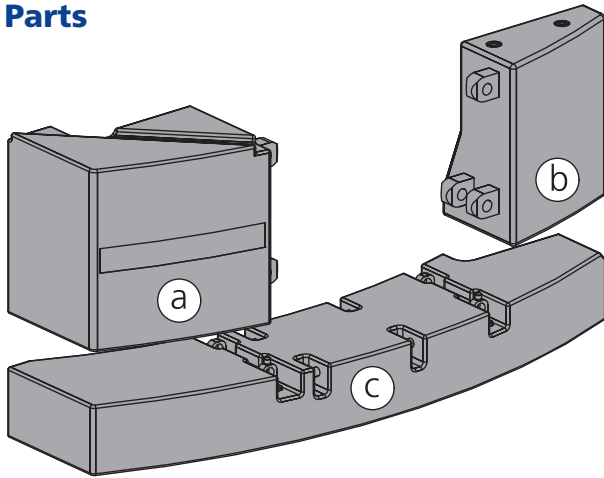

Configurations

	Ⓐ 4,400 lb	Ⓑ 2,000 lb	Ⓒ 5,300 lb
0 lb			
2,000 lb		X	
4,400 lb	X		
5,300 lb			X
6,400 lb	X	X	
7,300 lb		X	X
9,700 lb	X		X
11,700 lb	X	X	X

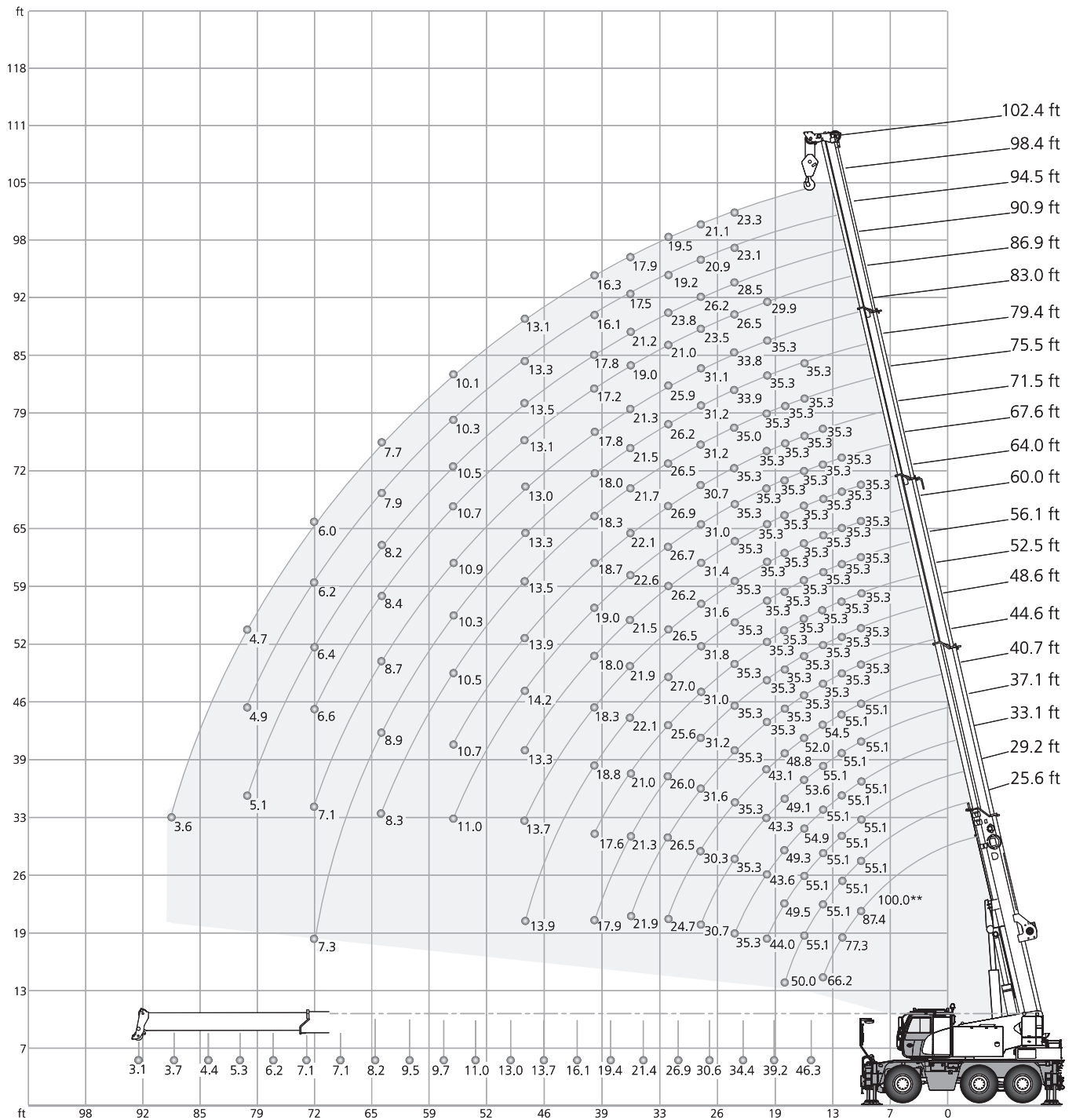

11,700 lb		20.3 ft x 21.0 ft										360°		ASME B30.5	
ft		25.6 ft*	25.6 ft	29.2 ft	33.1 ft	37.1 ft	40.7 ft	44.6 ft	48.6 ft	52.5 ft	56.1 ft	60.0 ft	64.0 ft	ft	
ft		1,000 lb												ft	
8	100.0**	-	-	-	-	-	-	-	-	-	-	-	-	8	
10	87.4	77.4	55.1	55.1	55.1	55.1	55.1	35.3	35.3	35.3	35.3	35.3	35.3	10	
12	77.3	71.9	55.1	55.1	55.1	55.1	55.1	35.3	35.3	35.3	35.3	35.3	35.3	12	
14	66.2	65.6	55.1	55.1	55.1	55.1	54.5	35.3	35.3	35.3	35.3	35.3	35.3	14	
16	-	-	55.1	55.1	54.9	53.6	52.0	35.3	35.3	35.3	35.3	35.3	35.3	16	
18	-	-	50.0	49.5	49.3	49.1	48.8	35.3	35.3	35.3	35.3	35.3	35.3	18	
20	-	-	-	44.0	43.6	43.3	43.1	35.3	35.3	35.3	35.3	35.3	35.3	20	
24	-	-	-	-	35.3	35.3	35.3	35.3	35.3	35.3	35.3	35.3	35.3	24	
28	-	-	-	-	-	30.7	30.3	31.6	31.2	31.0	31.8	31.8	31.6	28	
32	-	-	-	-	-	-	24.7	26.5	26.0	25.6	27.0	26.5	32	32	
36	-	-	-	-	-	-	-	21.9	21.3	21.0	22.1	21.9	36	36	
40	-	-	-	-	-	-	-	-	17.9	17.6	18.8	18.3	40	40	
48	-	-	-	-	-	-	-	-	-	-	13.9	13.7	48	48	
1)	46.3	46.3	39.2	34.4	30.6	26.9	21.4	19.4	16.1	13.7	13.0	11.0	1)	1)	

ft		67.6 ft	71.5 ft	75.5 ft	79.4 ft	83.0 ft	86.9 ft	90.9 ft	94.5 ft	98.4 ft	102.4 ft	ft	
ft		1,000 lb										ft	
10	35.3	-	-	-	-	-	-	-	-	-	-	-	10
12	35.3	35.3	-	-	-	-	-	-	-	-	-	-	12
14	35.3	35.3	35.3	-	-	-	-	-	-	-	-	-	14
16	35.3	35.3	35.3	35.3	-	-	-	-	-	-	-	-	16
18	35.3	35.3	35.3	35.3	35.3	-	-	-	-	-	-	-	18
20	35.3	35.3	35.3	35.3	35.3	35.3	29.9	-	-	-	-	-	20
24	35.3	35.3	35.3	35.0	33.9	33.7	26.5	28.5	23.1	23.3	24	24	
28	31.4	31.0	30.7	31.2	31.2	31.1	23.5	26.2	20.9	21.1	28	28	
32	26.2	26.7	26.9	26.5	26.2	25.9	21.0	23.8	19.2	19.5	32	32	
36	21.5	22.6	22.1	21.7	21.5	21.3	19.0	21.2	17.5	17.9	36	36	
40	18.0	19.0	18.7	18.3	18.0	17.8	17.2	17.8	16.1	16.3	40	40	
48	13.3	14.2	13.9	13.5	13.3	13.0	13.1	13.5	13.3	13.1	48	48	
56	-	11.0	10.7	10.5	10.3	10.9	10.7	10.5	10.3	10.1	56	56	
64	-	-	-	8.3	8.9	8.7	8.4	8.2	7.9	7.7	64	64	
72	-	-	-	-	7.3	7.1	6.6	6.4	6.2	6.0	72	72	
80	-	-	-	-	-	-	-	5.1	4.9	4.7	80	80	
88	-	-	-	-	-	-	-	-	-	3.6	88	88	
1)	9.7	9.5	8.2	7.1	7.1	6.2	5.3	4.4	3.7	3.1	1)	1)	

1) Capacities with horizontal boom

* 180° over front

** Capacity class

6,400 lb		20.3 ft x 21.0 ft										360° / Max.*				ASME B30.5	
ft	360° 25.6 ft	Max. 25.6 ft	360° 29.2 ft	Max. 29.2 ft	360° 33.1 ft	Max. 33.1 ft	360° 37.1 ft	Max. 37.1 ft	360° 40.7 ft	Max. 40.7 ft	360° 44.6 ft	Max. 44.6 ft	360° 48.6 ft	Max. 48.6 ft	ft		
1,000 lb																	
10	77.4	77.4	55.1	55.1	55.1	55.1	55.1	55.1	55.1	55.1	55.1	55.1	55.1	35.3	35.3		
12	71.6	71.6	55.1	55.1	55.1	55.1	55.1	55.1	55.1	55.1	55.1	55.1	55.1	35.3	35.3		
14	64.0	64.0	55.1	55.1	55.1	55.1	55.1	55.1	55.1	55.1	55.1	54.5	54.5	35.3	35.3		
16	-	-	53.6	53.6	53.3	53.3	53.1	53.1	53.0	53.0	52.0	52.0	52.0	35.3	35.3		
18	-	-	47.8	-	47.3	47.8	47.1	47.4	46.9	47.1	46.7	46.7	46.7	35.3	35.3		
20	-	-	-	-	41.8	41.9	41.6	41.6	41.4	41.4	41.2	41.2	35.3	35.3	20		
24	-	-	-	-	-	-	34.7	34.7	34.6	34.6	34.3	34.3	35.1	35.1	24		
28	-	-	-	-	-	-	-	-	27.4	28.8	26.7	28.3	28.7	29.8	28		
32	-	-	-	-	-	-	-	-	-	-	21.0	22.6	22.8	24.2	32		
36	-	-	-	-	-	-	-	-	-	-	-	-	18.6	-	36		
1)	46.3	46.3	39.2	39.2	34.4	34.4	29.3	30.6	22.9	24.5	18.1	19.4	16.5	17.6	1)		

ft	360° 52.5 ft	Max. 52.5 ft	360° 56.1 ft	Max. 56.1 ft	360° 60.0 ft	Max. 60.0 ft	360° 64.0 ft	Max. 64.0 ft	360° 67.6 ft	Max. 67.6 ft	360° 71.5 ft	Max. 71.5 ft	360° 75.5 ft	Max. 75.5 ft	ft
1,000 lb															
10	35.3	35.3	35.3	35.3	35.3	35.3	35.3	35.3	35.3	35.3	-	-	-	-	10
12	35.3	35.3	35.3	35.3	35.3	35.3	35.3	35.3	35.3	35.3	35.3	35.3	-	-	12
14	35.3	35.3	35.3	35.3	35.3	35.3	35.3	35.3	35.3	35.3	35.3	35.3	35.3	35.3	14
16	35.3	35.3	35.3	35.3	35.3	35.3	35.3	35.3	35.3	35.3	35.3	35.3	35.3	35.3	16
18	35.3	35.3	35.3	35.3	35.3	35.3	35.3	35.3	35.3	35.3	35.3	35.3	35.3	35.3	18
20	35.3	35.3	35.3	35.3	35.3	35.3	35.3	35.3	35.3	35.3	35.3	35.3	35.3	35.3	20
24	34.9	34.9	34.7	34.7	35.3	35.3	35.1	35.1	34.9	34.9	34.4	34.4	33.7	34.2	24
28	28.3	29.4	27.8	29.0	29.3	30.2	28.9	29.8	28.5	29.5	28.8	29.2	29.1	29.3	28
32	22.4	23.8	21.9	23.4	23.2	24.7	22.8	24.2	22.6	23.8	23.7	24.8	23.2	24.5	32
36	18.2	19.8	17.7	19.4	19.0	20.6	18.6	20.3	18.4	19.8	19.3	20.8	19.0	20.5	36
40	15.2	-	14.8	16.0	16.1	17.1	15.7	16.8	15.2	16.4	16.3	17.3	15.9	17.0	40
48	-	-	-	-	11.7	-	11.3	12.4	11.1	12.2	12.0	13.1	11.7	12.6	48
56	-	-	-	-	-	-	-	-	-	-	9.2	10.2	8.8	9.7	56
1)	13.7	14.6	11.5	12.3	10.8	11.7	9.3	10.1	7.7	8.8	7.7	8.6	6.6	7.5	1)

ft	360° 79.4 ft	Max. 79.4 ft	360° 83.0 ft	Max. 83.0 ft	360° 86.9 ft	Max. 86.9 ft	360° 90.9 ft	Max. 90.9 ft	360° 94.5 ft	Max. 94.5 ft	360° 98.4 ft	Max. 98.4 ft	360° 102.4 ft	Max. 102.4 ft	ft
1,000 lb															
16	35.3	35.3	-	-	-	-	-	-	-	-	-	-	-	-	16
18	35.3	35.3	35.3	35.3	-	-	-	-	-	-	-	-	-	-	18
20	35.3	35.3	35.3	35.3	35.3	35.3	29.9	29.9	-	25.6	-	-	-	-	20
24	33.7	34.1	33.5	33.6	32.9	33.3	26.5	26.6	28.5	28.5	23.1	23.2	23.3	23.3	24
28	28.3	29.5	27.4	29.1	26.8	28.4	23.5	23.6	26.1	26.3	20.9	21.0	21.1	21.2	28
32	22.8	24.2	22.6	23.7	22.1	23.4	21.0	21.0	21.7	23.0	19.2	19.2	19.5	19.5	32
36	18.6	20.3	18.4	19.8	18.2	19.6	17.7	18.5	18.2	19.5	17.5	17.6	17.9	17.9	36
40	15.7	16.8	15.2	16.4	15.0	16.2	15.5	16.0	15.7	16.2	15.5	16.0	15.2	16.2	40
48	11.3	12.4	12.0	12.2	12.0	12.5	11.5	12.6	11.3	12.4	11.1	12.2	10.9	12.0	48
56	8.5	9.5	9.4	10.1	9.0	10.0	8.8	9.7	8.5	9.5	8.3	9.3	8.1	9.1	56
64	6.5	7.4	7.4	8.1	7.0	7.9	6.7	7.7	6.5	7.4	6.3	7.2	6.1	7.0	64
72	-	-	5.8	6.6	5.5	6.4	5.3	6.2	4.9	5.8	4.7	5.5	4.4	5.5	72
80	-	-	-	-	-	-	-	-	3.8	-	3.6	4.5	3.4	4.2	80
88	-	-	-	-	-	-	-	-	-	-	-	-	2.5	3.3	88
1)	5.5	6.4	5.7	6.4	4.9	5.5	4.0	4.9	3.3	4.2	2.6	3.5	2.0	2.9	1)

1) Capacities with horizontal boom

* Max. values are valid only for specific superstructure positions

0 lb		20.3 ft x 21.0 ft														360° / Max.*		ASME B30.5	
		360°		Max.		360°		Max.		360°		Max.		360°		Max.			
		25.6 ft		25.6 ft		29.2 ft		29.2 ft		33.1 ft		33.1 ft		37.1 ft		37.1 ft		48.6 ft	
ft		1,000 lb														ft			
10		77.4	77.4	55.1	55.1	55.1	55.1	55.1	55.1	55.1	55.1	55.1	55.1	55.1	55.1	55.1	35.3	35.3	10
12		70.7	70.7	55.1	55.1	55.1	55.1	55.1	55.1	55.1	55.1	55.1	55.1	55.1	55.1	55.1	35.3	35.3	12
14		60.9	60.9	55.1	55.1	55.1	55.1	55.1	55.1	55.1	55.1	55.1	55.1	54.5	54.5	35.3	35.3	14	
16		-	-	51.3	51.3	51.1	51.1	50.8	50.8	50.6	50.6	50.2	50.2	35.3	35.3	16	16	16	
18		-	-	45.1	-	44.7	45.0	44.5	44.7	44.0	44.4	44.0	44.2	35.3	35.3	18	18	18	
20		-	-	-	-	39.1	39.5	38.8	39.0	38.5	38.8	38.3	38.6	35.3	35.3	20	20	20	
24		-	-	-	-	-	-	30.3	33.6	29.7	33.0	29.0	32.8	31.3	33.7	24	24	24	
28		-	-	-	-	-	-	-	-	22.1	27.5	21.5	27.2	23.4	28.3	28	28	28	
32		-	-	-	-	-	-	-	-	-	-	16.5	22.5	18.4	24.0	32	32	32	
36		-	-	-	-	-	-	-	-	-	-	-	-	14.8	-	36	36	36	
1)		46.3	46.3	39.2	39.2	30.9	34.0	23.8	28.7	18.3	24.3	14.1	19.4	13.0	17.6	1)	1)	1)	

		360°		Max.		360°		Max.		360°		Max.		360°		Max.			
		52.5 ft		52.5 ft		56.1 ft		56.1 ft		60.0 ft		60.0 ft		64.0 ft		64.0 ft		75.5 ft	
ft		1,000 lb														ft			
10		35.3	35.3	35.3	35.3	35.3	35.3	35.3	35.3	35.3	35.3	-	-	-	-	10	10	10	
12		35.3	35.3	35.3	35.3	35.3	35.3	35.3	35.3	35.3	35.3	35.3	35.3	-	-	12	12	12	
14		35.3	35.3	35.3	35.3	35.3	35.3	35.3	35.3	35.3	35.3	35.3	35.3	35.3	35.3	14	14	14	
16		35.3	35.3	35.3	35.3	35.3	35.3	35.3	35.3	35.3	35.3	35.3	35.3	35.3	35.3	16	16	16	
18		35.3	35.3	35.3	35.3	35.3	35.3	35.3	35.3	35.3	35.3	35.3	35.3	35.3	35.3	18	18	18	
20		35.3	35.3	35.3	35.3	35.3	35.3	35.3	35.3	35.3	35.3	35.3	35.3	35.0	35.2	20	20	20	
24		30.7	33.7	30.1	33.5	31.7	33.9	30.7	33.7	29.7	33.7	30.6	33.6	29.5	33.2	24	24	24	
28		23.0	28.1	22.3	27.8	23.9	28.7	23.4	28.3	23.0	28.1	24.3	28.5	23.7	28.6	28	28	28	
32		17.8	23.6	17.4	23.2	18.9	24.4	18.5	24.0	18.1	23.6	19.2	24.6	18.7	24.2	32	32	32	
36		14.4	19.8	14.0	19.4	15.3	20.6	14.8	20.3	14.4	19.8	15.5	20.8	15.1	20.5	36	36	36	
40		11.8	-	11.3	16.0	12.7	17.1	12.2	16.8	11.8	16.4	12.9	17.3	12.4	17.0	40	40	40	
48		-	-	-	-	9.1	-	8.6	12.4	8.3	12.2	9.3	13.1	8.9	12.6	48	48	48	
56		-	-	-	-	-	-	-	-	-	-	7.0	10.2	6.6	9.7	56	56	56	
1)		10.4	14.6	8.6	12.3	8.4	11.7	6.8	10.1	5.5	8.8	5.7	8.6	4.6	7.5	1)	1)	1)	

		360°		Max.		360°		Max.		360°		Max.		360°		Max.			
		79.4 ft		79.4 ft		83.0 ft		83.0 ft		86.9 ft		86.9 ft		90.9 ft		90.9 ft		102.4 ft	
ft		1,000 lb														ft			
16		35.3	35.3	-	-	-	-	-	-	-	-	-	-	-	-	-	-	16	16
18		35.3	35.3	35.3	35.3	-	-	-	-	-	-	-	-	-	-	-	-	18	18
20		35.0	35.3	34.8	35.2	34.6	35.2	29.9	29.9	-	25.6	-	-	-	-	-	20	20	20
24		28.6	33.6	27.7	33.2	26.8	33.0	25.9	26.6	26.0	28.4	23.1	23.2	23.3	23.3	24	24	24	24
28		22.8	28.3	22.1	28.1	21.5	27.9	20.8	23.6	20.8	26.3	20.8	21.0	20.2	21.2	28	28	28	28
32		18.5	24.0	18.1	23.6	18.0	23.4	18.2	21.0	17.8	23.0	17.2	19.1	16.7	19.5	32	32	32	32
36		14.8	20.3	15.7	19.8	15.5	19.6	15.1	18.5	14.8	19.5	14.4	17.6	13.9	17.9	36	36	36	36
40		12.2	16.8	13.1	16.4	12.8	16.2	12.4	16.0	12.2	16.2	12.0	16.0	11.8	16.2	40	40	40	40
48		8.6	12.4	9.5	12.2	9.1	12.5	8.9	12.6	8.6	12.4	8.4	12.2	8.2	12.0	48	48	48	48
56		6.1	9.5	7.0	10.1	6.8	10.0	6.6	9.7	6.1	9.5	5.9	9.3	5.7	9.1	56	56	56	56
64		4.5	7.4	5.4	8.1	5.1	7.9	4.7	7.7	4.5	7.4	4.3	7.2	4.1	7.0	64	64	64	64
72		-	-	4.0	6.6	3.8	6.4	3.6	6.2	3.1	5.8	2.9	5.5	2.7	5.5	72	72	72	72
80		-	-	-	-	-	-	-	-	-	-	2.3	-	2.0	4.5	80	80	80	80
88		-	-	-	-	-	-	-	-	-	-	-	-	-	3.3	88	88	88	88
1)		3.5	6.4	4.0	6.4	3.1	5.5	2.4	4.9	1.8	4.2	1.3	3.5	-	2.9	1)	1)	1)	1)

1) Capacities with horizontal boom

* Max. values are valid only for specific superstructure positions

		11,700 lb		14.4 ft x 21.0 ft		360° / Max.*		ASME B30.5								
ft	360° 25.6 ft	Max. 25.6 ft	360° 29.2 ft	Max. 29.2 ft	360° 33.1 ft	Max. 33.1 ft	360° 37.1 ft	Max. 37.1 ft	360° 40.7 ft	Max. 40.7 ft	360° 44.6 ft	Max. 44.6 ft	360° 48.6 ft	Max. 48.6 ft	ft	
1,000 lb																
10	75.3	77.4	55.1	55.1	55.1	55.1	55.1	55.1	55.1	55.1	55.1	55.1	55.1	35.3	35.3	10
12	66.3	71.9	55.1	55.1	55.1	55.1	55.1	55.1	55.1	55.1	55.1	55.1	55.1	35.3	35.3	12
14	56.2	65.6	52.8	55.1	52.4	55.1	52.2	55.1	51.7	55.1	50.5	54.5	35.3	35.3	14	
16	-	-	43.1	55.1	42.6	55.1	42.1	54.9	41.6	53.6	40.9	51.9	35.3	35.3	16	
18	-	-	33.9	-	35.1	50.0	35.3	49.7	35.3	48.7	35.1	47.6	35.3	35.3	18	
20	-	-	-	-	29.0	43.8	30.1	43.6	29.4	43.4	29.0	43.2	30.8	35.3	20	
24	-	-	-	-	-	-	21.9	34.8	21.4	34.6	21.0	34.3	22.6	34.8	24	
28	-	-	-	-	-	-	-	-	16.4	29.2	16.0	28.7	17.5	30.4	28	
32	-	-	-	-	-	-	-	-	-	12.7	22.6	14.0	24.2	32	32	
36	-	-	-	-	-	-	-	-	-	-	-	-	11.5	-	36	
1)	44.1	46.3	29.5	39.2	22.3	34.4	17.6	30.6	13.9	24.5	11.0	19.4	10.4	17.6	1)	

ft	360° 52.5 ft	Max. 52.5 ft	360° 56.1 ft	Max. 56.1 ft	360° 60.0 ft	Max. 60.0 ft	360° 64.0 ft	Max. 64.0 ft	360° 67.6 ft	Max. 67.6 ft	360° 71.5 ft	Max. 71.5 ft	360° 75.5 ft	Max. 75.5 ft	ft
1,000 lb															
10	35.3	35.3	35.3	35.3	35.3	35.3	35.3	35.3	35.3	35.3	-	-	-	-	10
12	35.3	35.3	35.3	35.3	35.3	35.3	35.3	35.3	35.3	35.3	35.3	35.3	-	-	12
14	35.3	35.3	35.3	35.3	35.3	35.3	35.3	35.3	35.3	35.3	35.3	35.3	35.3	35.3	14
16	35.3	35.3	35.3	35.3	35.3	35.3	35.3	35.3	35.3	35.3	35.3	35.3	35.3	35.3	16
18	35.3	35.3	35.3	35.3	35.3	35.3	35.1	35.3	34.0	35.3	34.6	35.3	33.3	35.3	18
20	30.3	35.3	29.9	35.3	31.2	35.3	30.8	35.3	29.8	35.3	30.5	35.3	29.5	35.3	20
24	22.1	34.6	21.7	34.5	23.0	35.0	22.6	34.9	22.1	34.7	23.2	34.4	22.8	34.2	24
28	17.1	30.0	16.7	29.6	17.8	31.0	17.5	30.5	17.1	30.2	18.0	29.6	17.8	29.3	28
32	13.7	23.8	13.3	23.4	14.3	24.7	14.0	24.2	13.8	23.8	14.5	24.8	14.3	24.5	32
36	11.3	19.8	10.9	19.4	12.0	20.6	11.5	20.3	11.3	19.8	12.0	20.8	11.7	20.5	36
40	9.4	-	9.0	16.0	9.9	17.1	9.7	16.8	9.4	16.4	10.1	17.3	9.9	17.0	40
48	-	-	-	-	7.4	-	7.2	12.4	6.7	12.2	7.6	13.1	7.2	12.6	48
56	-	-	-	-	-	-	-	-	-	-	5.7	10.2	5.5	9.7	56
1)	8.4	14.6	7.1	12.3	6.8	11.7	5.7	10.1	4.9	8.8	4.9	8.6	4.0	7.5	1)

ft	360° 79.4 ft	Max. 79.4 ft	360° 83.0 ft	Max. 83.0 ft	360° 86.9 ft	Max. 86.9 ft	360° 90.9 ft	Max. 90.9 ft	360° 94.5 ft	Max. 94.5 ft	360° 98.4 ft	Max. 98.4 ft	360° 102.4 ft	Max. 102.4 ft	ft
1,000 lb															
16	35.3	35.3	-	-	-	-	-	-	-	-	-	-	-	-	16
18	32.3	35.3	31.2	35.3	-	-	-	-	-	-	-	-	-	-	18
20	28.6	35.3	27.7	35.2	26.8	35.2	26.0	29.9	25.5	25.6	-	-	-	-	20
24	22.5	34.1	22.1	33.6	22.2	33.3	22.0	26.6	21.4	28.4	20.7	23.2	20.2	23.3	24
28	17.5	29.5	18.2	29.1	18.0	28.4	17.8	23.6	17.5	26.3	17.1	21.0	16.7	21.2	28
32	14.0	24.2	14.8	23.7	14.5	23.4	14.3	21.0	14.1	23.0	13.9	19.1	13.7	19.5	32
36	11.5	20.3	12.2	19.8	12.0	19.6	11.7	18.5	11.5	19.5	11.3	17.6	11.3	17.9	36
40	9.7	16.8	10.3	16.4	10.1	16.2	9.9	16.0	9.7	16.2	9.4	16.0	9.2	16.2	40
48	6.9	12.4	7.6	12.2	7.4	12.5	7.2	12.6	7.0	12.4	6.9	12.2	6.7	12.0	48
56	5.2	9.5	5.9	10.1	5.7	10.0	5.5	9.7	5.2	9.5	5.0	9.3	5.0	9.1	56
64	4.0	7.4	4.6	8.1	4.4	7.9	4.2	7.7	4.0	7.4	3.7	7.2	3.7	7.0	64
72	-	-	3.6	6.6	3.3	6.4	3.3	6.2	3.1	5.8	2.9	5.5	2.7	5.5	72
80	-	-	-	-	-	-	-	-	2.3	-	2.1	4.5	1.9	4.2	80
88	-	-	-	-	-	-	-	-	-	-	-	-	-	3.3	88
1)	3.3	6.4	3.5	6.4	2.9	5.5	2.4	4.9	2.0	4.2	1.5	3.5	-	2.9	1)

1) Capacities with horizontal boom

* Max. values are valid only for specific superstructure positions

		11,700 lb				7.7 ft x 21.0 ft				360° / Max.*				ASME B30.5	
ft	360°	Max.	360°	Max.	360°	Max.	360°	Max.	360°	Max.	360°	Max.	360°	Max.	ft
	25.6 ft	25.6 ft	29.2 ft	29.2 ft	33.1 ft	33.1 ft	37.1 ft	37.1 ft	40.7 ft	40.7 ft	44.6 ft	44.6 ft	48.6 ft	48.6 ft	
1,000 lb															
10	-	77.4	-	55.1	-	55.1	-	55.1	-	55.1	-	55.1	-	35.3	10
12	-	71.9	-	55.1	-	55.1	-	55.1	-	55.1	-	55.1	-	35.3	12
14	-	65.6	-	55.1	-	55.1	-	55.1	-	55.1	-	54.5	-	35.3	14
16	-	-	17.8	55.1	18.9	55.1	19.6	54.9	19.1	53.6	18.7	51.9	20.3	35.3	16
18	-	-	14.6	-	15.5	50.0	16.2	49.7	15.7	48.7	15.5	47.6	16.8	35.3	18
20	-	-	-	-	13.1	43.8	13.8	43.6	13.3	43.4	12.9	43.2	14.3	35.3	20
24	-	-	-	-	-	-	10.3	34.8	9.9	34.6	9.5	34.3	10.8	34.8	24
28	-	-	-	-	-	-	-	-	7.7	29.2	7.2	28.7	8.3	30.4	28
32	-	-	-	-	-	-	-	-	-	-	5.6	22.6	6.7	24.2	32
36	-	-	-	-	-	-	-	-	-	-	-	-	5.5	-	36
1)	-	46.3	12.8	39.2	10.1	34.4	8.4	30.6	6.4	24.5	4.9	19.4	4.9	17.6	1)

		360°				360°				360°				ASME B30.5	
ft	360°	Max.	360°	Max.	360°	Max.	360°	Max.	360°	Max.	360°	Max.	360°	Max.	ft
	52.5 ft	52.5 ft	56.1 ft	56.1 ft	60.0 ft	60.0 ft	64.0 ft	64.0 ft	67.6 ft	67.6 ft	71.5 ft	71.5 ft	75.5 ft	75.5 ft	
1,000 lb															
10	-	35.3	-	35.3	-	35.3	-	35.3	-	35.3	-	-	-	-	10
12	-	35.3	-	35.3	-	35.3	-	35.3	-	35.3	-	35.3	-	-	12
14	-	35.3	-	35.3	-	35.3	-	35.3	-	35.3	-	35.3	-	35.3	14
16	19.8	35.3	19.6	35.3	20.7	35.3	20.1	35.3	19.6	35.3	20.4	35.3	19.5	35.3	16
18	16.4	35.3	16.2	35.3	17.3	35.3	16.8	35.3	16.6	35.3	17.5	35.3	17.0	35.3	18
20	14.0	35.3	13.6	35.3	14.7	35.3	14.4	35.3	14.0	35.3	14.9	35.3	14.7	35.3	20
24	10.4	34.6	10.1	34.5	11.1	35.0	10.8	34.9	10.5	34.7	11.3	34.4	11.0	34.2	24
28	8.1	30.0	7.9	29.6	8.8	31.0	8.3	30.5	8.1	30.2	8.8	29.6	8.6	29.3	28
32	6.4	23.8	6.2	23.4	6.9	24.7	6.7	24.2	6.5	23.8	7.2	24.8	6.9	24.5	32
36	5.1	19.8	4.9	19.4	5.8	20.6	5.3	20.3	5.1	19.8	5.8	20.8	5.5	20.5	36
40	4.2	-	3.9	16.0	4.7	17.1	4.5	16.8	4.2	16.4	4.9	17.3	4.7	17.0	40
48	-	-	-	-	3.2	-	3.0	12.4	2.8	12.2	3.5	13.1	3.2	12.6	48
56	-	-	-	-	-	-	-	-	-	-	2.4	10.2	2.2	9.7	56
1)	3.7	14.6	2.9	12.3	3.1	11.7	2.2	10.1	1.8	8.8	2.0	8.6	1.3	7.5	1)

		360°				360°				360°				ASME B30.5	
ft	360°	Max.	360°	Max.	360°	Max.	360°	Max.	360°	Max.	360°	Max.	360°	Max.	ft
	79.4 ft	79.4 ft	83.0 ft	83.0 ft	86.9 ft	86.9 ft	90.9 ft	90.9 ft	94.5 ft	94.5 ft	98.4 ft	98.4 ft	102.4 ft	102.4 ft	
1,000 lb															
16	18.8	35.3	-	-	-	-	-	-	-	-	-	-	-	-	16
18	16.4	35.3	17.0	35.3	-	-	-	-	-	-	-	-	-	-	18
20	14.4	35.3	15.1	35.2	14.5	35.2	14.1	29.9	13.6	25.6	-	-	-	-	20
24	10.8	34.1	11.5	33.6	11.2	33.3	11.0	26.6	10.8	28.4	10.5	23.2	10.0	23.3	24
28	8.3	29.5	9.0	29.1	8.8	28.4	8.6	23.6	8.3	26.3	8.3	21.0	8.1	21.2	28
32	6.7	24.2	7.4	23.7	7.2	23.4	6.9	21.0	6.7	23.0	6.5	19.1	6.4	19.5	32
36	5.3	20.3	6.0	19.8	5.8	19.6	5.5	18.5	5.5	19.5	5.3	17.6	5.1	17.9	36
40	4.5	16.8	5.0	16.4	4.8	16.2	4.7	16.0	4.5	16.2	4.2	16.0	4.1	16.2	40
48	3.0	12.4	3.5	12.2	3.2	12.5	3.2	12.6	3.0	12.4	2.8	12.2	2.6	12.0	48
56	2.0	9.5	2.4	10.1	2.4	10.0	2.2	9.7	2.0	9.5	1.7	9.3	-	9.1	56
64	-	7.4	1.8	8.1	1.7	7.9	-	7.7	-	7.4	-	7.2	-	7.0	64
72	-	-	-	6.6	-	6.4	-	6.2	-	5.8	-	5.5	-	5.5	72
80	-	-	-	-	-	-	-	-	-	-	-	4.5	-	4.2	80
88	-	-	-	-	-	-	-	-	-	-	-	-	-	3.3	88
1)	-	6.4	-	6.4	-	5.5	-	4.9	-	4.2	-	3.5	-	2.9	1)

1) Capacities with horizontal boom

* Max. values are valid only for specific superstructure positions

11,700 lb		0° *		ASME B30.5	
ft	25.6 ft	33.1 ft	40.7 ft	44.6 ft	
1,000 lb					
10	35.8	35.1	34.9	34.7	
12	30.9	30.5	30.0	30.0	
14	27.1	26.7	26.2	25.9	
16	-	23.5	22.9	22.1	
18	-	19.3	18.6	18.4	
20	-	15.9	15.5	15.2	
24	-	-	10.9	10.7	
28	-	-	8.1	7.9	
32	-	-	-	5.8	
1)	23.8	12.1	6.6	4.9	

11,700 lb		180° **		ASME B30.5	
ft	25.6 ft	33.1 ft	40.7 ft	44.6 ft	
1,000 lb					
10	25.9	25.5	25.0	24.8	
12	22.1	21.7	21.3	21.2	
14	19.1	18.7	18.4	18.2	
16	-	16.3	15.9	15.9	
18	-	14.2	13.9	13.7	
20	-	12.5	12.1	12.1	
24	-	-	9.6	9.4	
28	-	-	7.5	7.2	
32	-	-	-	5.6	
1)	16.5	10.1	6.2	4.6	

11,700 lb		360°		ASME B30.5	
ft	25.6 ft	33.1 ft	40.7 ft	44.6 ft	
1,000 lb					
14	14.9	14.4	14.0	13.8	
16	-	12.1	11.7	11.5	
18	-	10.2	9.7	9.7	
20	-	8.6	8.2	8.2	
24	-	-	5.8	5.8	
28	-	-	4.1	3.9	
32	-	-	-	2.6	
1)	12.3	6.4	2.9	1.8	





1) Capacities with horizontal boom

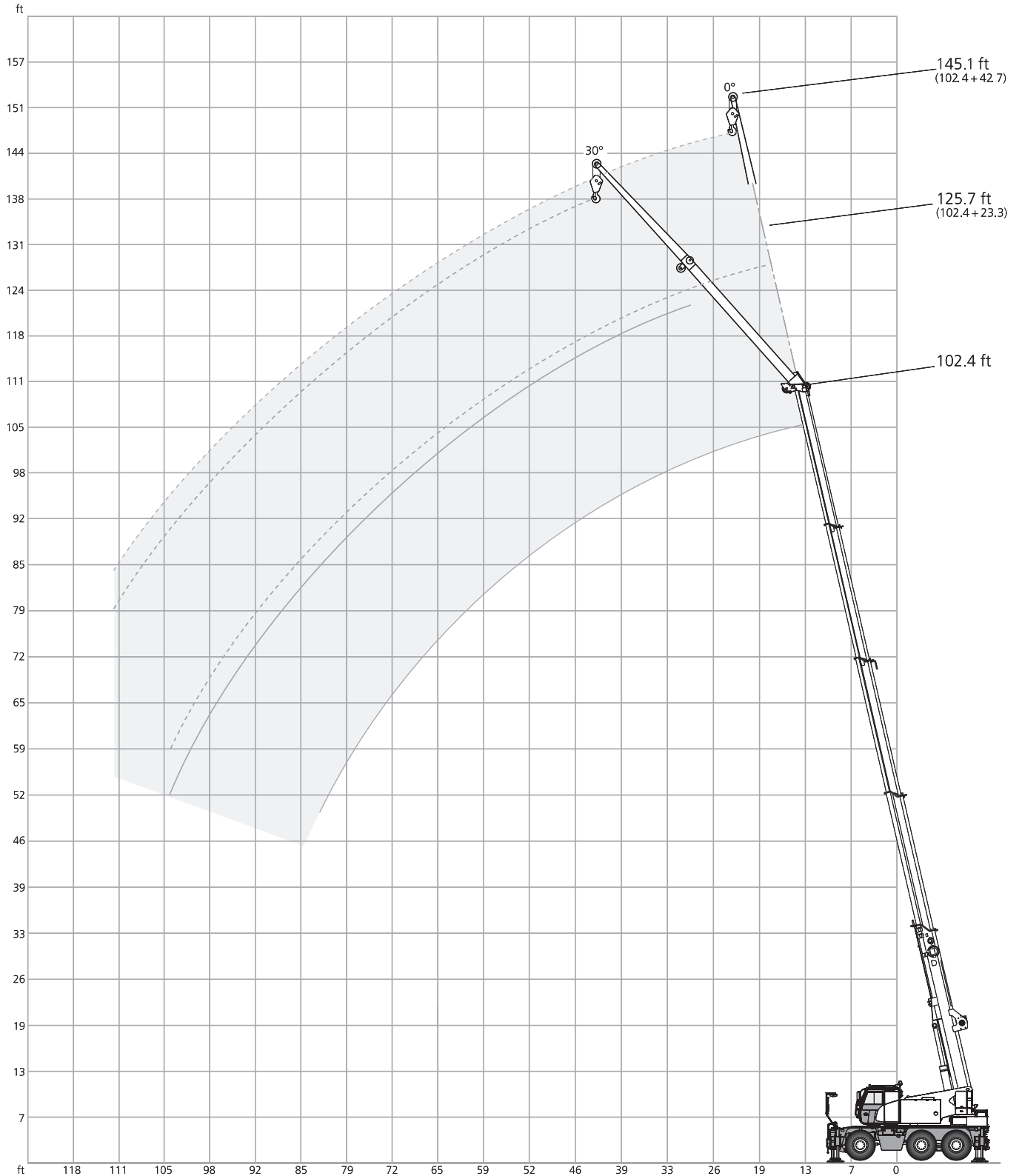
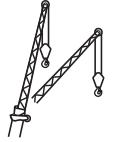

* over rear

** over front

A large rectangular area with horizontal lines, intended for taking notes.



 0 lb		 20.3 ft x 21.0 ft										360°										ASME B30.5									
 23.3 ft		(ft)										(ft)																			
 25.6 33.1 40.7 48.6 56.1 64.0 71.5 79.4 86.9 94.5 102.4		0°										30°																			
ft	1,000 lb																				ft										
10	18.2	19.3	19.4	19.4	-	-	-	-	-	-	-	-	-	-	-	-	-	-	-	-	-	10									
12	16.6	18.4	19.3	19.4	-	-	-	-	-	-	-	-	-	-	-	-	-	-	-	-	-	12									
14	15.4	17.0	18.6	19.4	19.4	-	-	-	-	-	-	-	-	-	-	-	-	-	-	-	-	14									
16	14.3	15.9	17.4	18.7	19.4	-	-	-	-	-	-	-	-	-	-	-	-	-	-	-	-	16									
18	13.5	15.0	16.3	17.7	18.5	19.2	-	-	-	-	-	-	-	-	-	-	-	-	-	-	-	18									
20	12.4	14.2	15.5	16.6	17.7	18.4	18.6	-	-	-	-	-	-	-	-	-	-	-	-	-	-	20									
24	11.2	12.6	13.9	15.0	15.9	16.8	17.0	17.4	-	-	-	-	-	-	-	-	-	-	-	-	-	24									
28	10.1	11.4	12.5	13.6	14.5	15.2	15.6	16.1	16.1	15.8	-	-	-	-	-	-	-	-	-	-	-	28									
32	9.1	10.4	11.5	12.6	13.4	14.1	14.5	15.0	15.0	14.9	13.4	-	-	-	-	-	-	-	-	-	-	32									
36	8.4	9.5	10.6	11.5	12.6	13.2	13.5	14.1	14.1	13.7	12.8	9.7	9.9	10.4	10.6	11.0	11.3	11.3	11.5	-	-	36									
40	-	8.9	9.8	10.7	11.6	12.2	12.5	12.8	12.0	11.9	11.4	-	9.7	10.1	10.3	10.7	10.9	11.0	11.2	11.2	-	40									
48	-	-	8.5	9.4	9.2	9.5	10.0	9.3	9.5	9.0	8.3	-	-	9.6	9.8	9.7	10.1	10.2	10.0	9.7	9.7	8.7	48								
56	-	-	-	7.5	6.8	7.2	7.4	6.8	7.2	6.6	6.1	-	-	-	-	7.2	7.7	7.9	7.5	7.9	7.4	7.0	56								
64	-	-	-	-	5.0	5.4	5.6	5.0	5.2	4.7	4.3	-	-	-	-	-	5.7	6.1	5.6	5.8	5.4	5.2	64								
72	-	-	-	-	-	4.0	4.2	3.6	4.0	3.3	2.9	-	-	-	-	-	-	4.7	4.0	4.4	4.0	3.6	72								
80	-	-	-	-	-	-	3.2	2.7	2.9	2.3	1.9	-	-	-	-	-	-	-	2.9	3.1	2.7	2.5	80								
88	-	-	-	-	-	-	-	1.8	2.0	1.6	-	-	-	-	-	-	-	-	-	2.3	1.8	1.6	88								

 42.7 ft		(ft)										(ft)											
 25.6 33.1 40.7 48.6 56.1 64.0 71.5 79.4 86.9 94.5 102.4		0°										30°											
ft	1,000 lb																				ft		
10	13.6	-	-	-	-	-	-	-	-	-	-	-	-	-	-	-	-	-	-	-	-	10	
12	12.5	13.4	-	-	-	-	-	-	-	-	-	-	-	-	-	-	-	-	-	-	-	12	
14	11.6	12.4	13.1	-	-	-	-	-	-	-	-	-	-	-	-	-	-	-	-	-	-	14	
16	10.7	11.6	12.3	12.7	-	-	-	-	-	-	-	-	-	-	-	-	-	-	-	-	-	16	
18	9.9	10.8	11.5	12.1	-	-	-	-	-	-	-	-	-	-	-	-	-	-	-	-	-	18	
20	9.4	10.2	10.9	11.4	11.8	12.0	-	-	-	-	-	-	-	-	-	-	-	-	-	-	-	20	
24	8.3	9.0	9.6	10.3	10.7	11.0	10.9	-	-	-	-	-	-	-	-	-	-	-	-	-	-	24	
28	7.5	8.1	8.8	9.2	9.7	10.1	10.1	10.1	-	-	-	-	-	-	-	-	-	-	-	-	-	28	
32	6.7	7.4	7.9	8.5	8.9	9.1	9.4	9.6	9.4	-	-	6.2	6.4	-	-	-	-	-	-	-	-	32	
36	6.0	6.6	7.3	7.7	8.2	8.4	8.6	8.8	8.8	8.4	-	5.7	6.0	6.2	-	-	-	-	-	-	-	36	
40	5.6	6.1	6.7	7.2	7.6	7.9	8.1	8.3	8.3	7.9	7.7	5.5	5.7	5.9	5.9	6.1	6.1	-	-	-	-	40	
48	4.7	5.2	5.7	6.1	6.6	6.9	7.1	7.4	7.4	7.1	7.1	4.9	5.2	5.4	5.4	5.6	5.6	5.7	5.8	-	-	48	
56	-	4.6	5.1	5.5	5.7	6.1	6.4	6.6	6.8	6.4	6.1	-	4.6	4.9	5.1	5.1	5.3	5.3	5.5	5.5	5.5	5.5	56
64	-	4.2	4.5	4.7	5.2	5.4	5.6	5.6	5.5	5.2	4.5	-	-	4.6	4.7	4.9	5.0	5.1	5.1	5.2	5.2	5.2	64
72	-	-	4.2	4.4	4.4	4.7	4.7	4.2	4.2	3.8	3.3	-	-	-	4.6	4.6	4.6	4.9	4.9	4.9	4.9	4.7	72
80	-	-	-	-	3.4	3.6	3.7	3.1	3.2	2.7	2.3	-	-	-	-	3.8	4.2	4.2	3.9	4.0	3.8	3.4	80
88	-	-	-	-	2.7	2.7	2.9	2.2	2.5	2.0	1.4	-	-	-	-	-	2.9	3.3	2.9	3.1	2.7	2.3	88
96	-	-	-	-	-	-	2.1	1.6	1.7	-	-	-	-	-	-	-	-	-	2.1	2.1	1.9	-	96
104	-	-	-	-	-	-	-	-	-	-	-	-	-	-	-	-	-	-	-	1.6	-	-	104

A large rectangular area with horizontal lines, intended for taking notes.

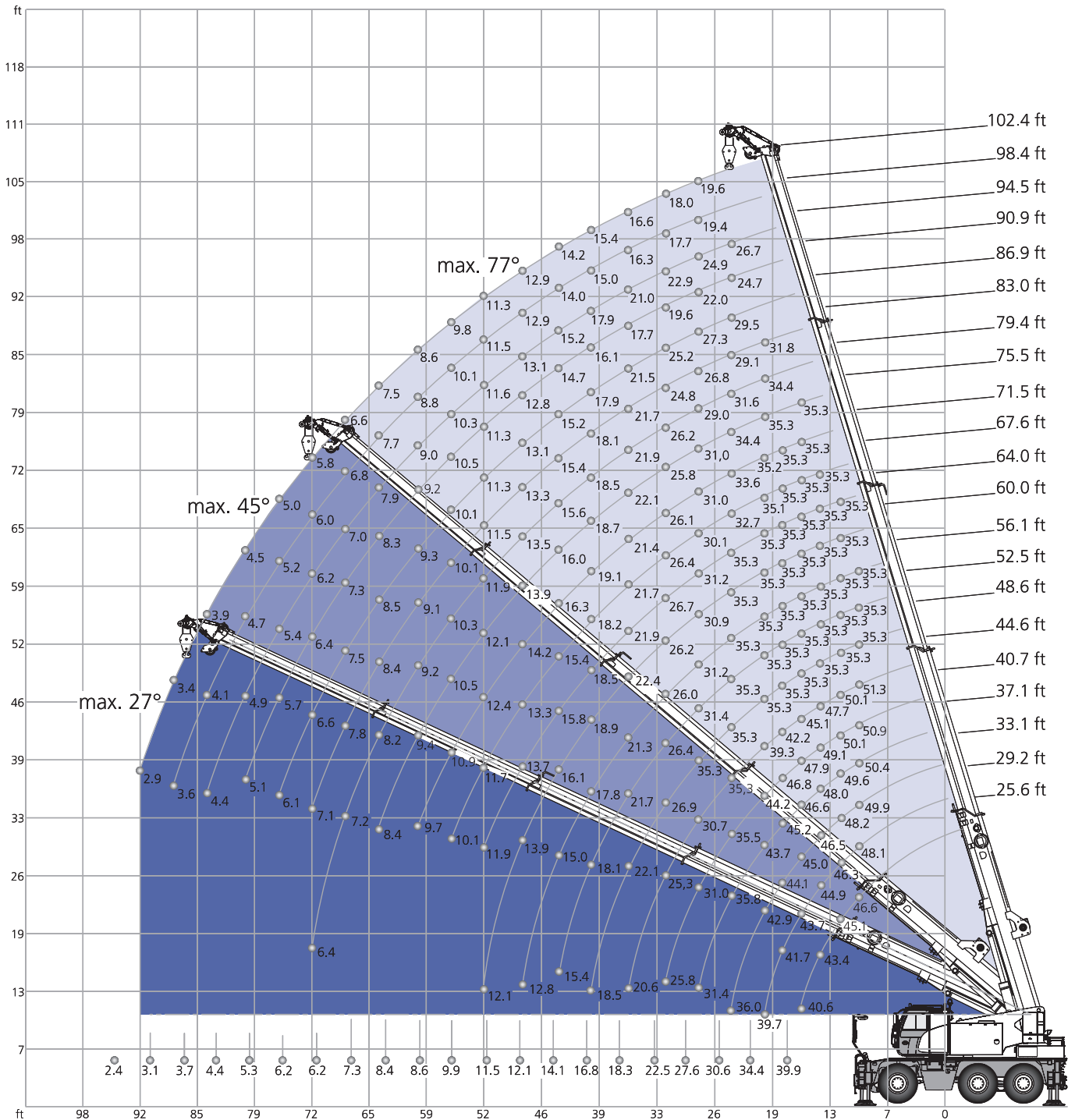
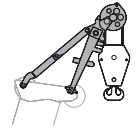

11,700 lb		20.3 ft x 21.0 ft					30°		360°		ASME B30.5	
ft	25.6 ft	29.2 ft	33.1 ft	37.1 ft	40.7 ft	44.6 ft	48.6 ft	52.5 ft	56.1 ft	60.0 ft	64.0 ft	ft
	1,000 lb											
10	46.6	48.1	49.9	50.4	50.9	51.3	35.3	35.3	35.3	35.3	-	10
12	45.1	46.3	48.2	49.6	50.1	50.1	35.3	35.3	35.3	35.3	35.3	12
14	43.4	44.9	46.5	48.0	49.1	47.7	35.3	35.3	35.3	35.3	35.3	14
16	40.6	43.7	45.0	46.6	47.9	45.1	35.3	35.3	35.3	35.3	35.3	16
18	39.9	41.7	44.1	45.2	46.8	42.2	35.3	35.3	35.3	35.3	35.3	18
20	-	39.7	42.9	43.7	44.2	39.3	35.3	35.3	35.3	35.3	35.3	20
24	-	-	36.0	35.8	35.5	35.3	35.3	35.3	35.3	35.3	35.3	24
28	-	-	-	31.4	31.0	30.7	31.8	31.4	31.2	30.9	31.2	28
32	-	-	-	-	25.8	25.3	26.9	26.4	26.0	26.2	26.7	32
36	-	-	-	-	-	20.6	22.1	21.7	21.3	22.4	21.9	36
40	-	-	-	-	-	-	18.5	18.1	17.8	18.9	18.5	40
44	-	-	-	-	-	-	-	15.4	15.0	16.1	15.8	44
48	-	-	-	-	-	-	-	-	12.8	13.9	13.7	48
52	-	-	-	-	-	-	-	-	-	12.1	11.9	52
1)	39.9	34.4	30.6	27.6	22.5	18.3	16.8	14.1	12.1	11.5	9.9	1)

ft	67.6 ft	71.5 ft	75.5 ft	79.4 ft	83.0 ft	86.9 ft	90.9 ft	94.5 ft	98.4 ft	102.4 ft	ft
	1,000 lb										
14	35.3	-	-	-	-	-	-	-	-	-	14
16	35.3	35.3	-	-	-	-	-	-	-	-	16
18	35.3	35.3	35.3	-	-	-	-	-	-	-	18
20	35.1	35.3	35.3	34.4	31.8	-	-	-	-	-	20
24	32.7	33.6	34.4	31.6	29.1	29.5	24.7	26.7	-	-	24
28	30.1	31.0	31.0	29.0	26.8	27.3	22.0	24.9	19.4	19.6	28
32	26.4	26.1	25.8	26.2	24.8	25.2	19.6	22.9	17.7	18.0	32
36	21.7	21.4	22.1	21.9	21.7	21.5	17.7	21.0	16.3	16.6	36
40	18.2	19.1	18.7	18.5	18.1	17.9	16.1	17.9	15.0	15.4	40
44	15.4	16.3	16.0	15.6	15.4	15.2	14.7	15.2	14.0	14.2	44
48	13.3	14.2	13.9	13.5	13.3	13.1	12.8	13.1	12.9	12.9	48
52	11.7	12.4	12.1	11.9	11.5	11.3	11.3	11.6	11.5	11.3	52
56	10.1	10.9	10.5	10.3	10.1	10.1	10.5	10.3	10.1	9.8	56
60	-	9.7	9.4	9.2	9.1	9.3	9.2	9.0	8.8	8.6	60
64	-	-	8.4	8.2	8.4	8.5	8.3	7.9	7.7	7.5	64
68	-	-	-	7.2	7.8	7.5	7.3	7.0	6.8	6.6	68
72	-	-	-	6.4	7.1	6.6	6.4	6.2	6.0	5.8	72
76	-	-	-	-	-	6.1	5.7	5.4	5.2	5.0	76
80	-	-	-	-	-	-	5.1	4.9	4.7	4.5	80
84	-	-	-	-	-	-	-	4.4	4.1	3.9	84
88	-	-	-	-	-	-	-	-	3.6	3.4	88
92	-	-	-	-	-	-	-	-	-	2.9	92
1)	8.6	8.4	7.3	6.2	6.2	5.3	4.4	3.7	3.1	2.4	1)

1) Capacities with horizontal boom

6,400 lb		20.3 ft x 21.0 ft										30°		360°		ASME B30.5	
		25.6 ft	29.2 ft	33.1 ft	37.1 ft	40.7 ft	44.6 ft	48.6 ft	52.5 ft	56.1 ft	60.0 ft	64.0 ft					
ft		1,000 lb										ft					
10		46.6	48.1	49.9	50.4	50.9	51.3	35.3	35.3	35.3	35.3	-	10				
12		45.1	46.3	48.2	49.6	50.1	50.1	35.3	35.3	35.3	35.3	35.3	12				
14		43.4	44.9	46.5	48.0	49.1	47.7	35.3	35.3	35.3	35.3	35.3	14				
16		40.6	43.7	45.0	46.6	47.9	45.1	35.3	35.3	35.3	35.3	35.3	16				
18		39.9	41.7	44.1	45.2	46.8	42.2	35.3	35.3	35.3	35.3	35.3	18				
20		-	39.7	42.5	42.4	42.2	39.3	35.3	35.3	35.3	35.3	35.3	20				
24		-	-	34.6	35.0	34.7	34.6	35.3	35.0	34.9	34.7	34.9	24				
28		-	-	-	28.7	28.0	27.6	29.3	28.7	28.3	28.3	29.1	28				
32		-	-	-	-	22.1	21.7	23.2	22.8	22.4	23.6	23.1	32				
36		-	-	-	-	-	17.5	19.0	18.6	18.2	19.3	18.8	36				
40		-	-	-	-	-	-	15.9	15.5	15.0	16.1	15.7	40				
44		-	-	-	-	-	-	-	12.9	12.5	13.6	13.4	44				
48		-	-	-	-	-	-	-	-	10.6	11.7	11.5	48				
52		-	-	-	-	-	-	-	-	-	10.1	9.9	52				
1)		39.9	34.4	29.8	24.0	19.2	15.4	14.3	11.7	9.9	9.5	7.9	1)				

		67.6 ft	71.5 ft	75.5 ft	79.4 ft	83.0 ft	86.9 ft	90.9 ft	94.5 ft	98.4 ft	102.4 ft		
ft		1,000 lb										ft	
14		35.3	-	-	-	-	-	-	-	-	-	-	14
16		35.3	35.3	-	-	-	-	-	-	-	-	-	16
18		35.3	35.3	35.3	-	-	-	-	-	-	-	-	18
20		35.1	35.3	35.3	34.4	31.8	-	-	-	-	-	-	20
24		32.7	33.6	33.5	31.6	29.1	29.5	24.7	26.7	-	-	-	24
28		28.9	28.1	27.2	27.2	26.8	26.5	22.0	24.9	19.4	19.6	-	28
32		22.8	23.0	23.2	23.0	22.6	21.9	19.6	21.5	17.7	18.0	-	32
36		18.6	19.5	19.3	18.8	18.6	18.4	17.7	18.1	16.3	16.6	-	36
40		15.5	16.3	16.0	15.7	15.5	15.2	15.0	15.2	15.0	15.1	-	40
44		12.9	13.8	13.6	13.2	12.9	12.9	13.3	13.2	12.9	12.7	-	44
48		11.1	12.0	11.7	11.3	11.3	11.7	11.5	11.3	11.1	10.9	-	48
52		9.5	10.3	10.1	9.9	10.5	10.1	9.9	9.7	9.5	9.2	-	52
56		8.3	9.0	8.8	8.5	9.2	9.0	8.7	8.5	8.1	7.9	-	56
60		-	8.0	7.7	7.5	8.1	7.7	7.5	7.2	7.0	6.8	-	60
64		-	-	6.7	6.4	7.2	6.8	6.6	6.3	6.1	5.8	-	64
68		-	-	-	5.5	6.4	5.9	5.7	5.5	5.3	5.0	-	68
72		-	-	-	4.9	5.5	5.3	4.9	4.7	4.4	4.2	-	72
76		-	-	-	-	-	4.6	4.3	4.1	3.9	3.7	-	76
80		-	-	-	-	-	-	3.8	3.6	3.4	3.1	-	80
84		-	-	-	-	-	-	-	3.0	2.8	2.6	-	84
88		-	-	-	-	-	-	-	-	2.5	2.2	-	88
92		-	-	-	-	-	-	-	-	-	1.8	-	92
1)		6.8	6.8	5.5	4.6	4.9	4.0	3.3	2.6	2.0	1.5	-	1)

1) Capacities with horizontal boom

0 lb		20.3 ft x 21.0 ft										30°	360°	ASME B30.5
		25.6 ft	29.2 ft	33.1 ft	37.1 ft	40.7 ft	44.6 ft	48.6 ft	52.5 ft	56.1 ft	60.0 ft	64.0 ft		
ft		1,000 lb											ft	
10		46.6	48.1	49.9	50.4	50.9	51.3	35.3	35.3	35.3	35.3	-	10	
12		45.1	46.3	48.2	49.6	50.1	50.1	35.3	35.3	35.3	35.3	35.3	12	
14		43.4	44.9	46.5	48.0	49.1	47.7	35.3	35.3	35.3	35.3	35.3	14	
16		40.6	43.7	45.0	46.6	47.9	45.1	35.3	35.3	35.3	35.3	35.3	16	
18		39.9	41.7	44.1	45.2	45.0	42.2	35.3	35.3	35.3	35.3	35.3	18	
20		-	39.2	40.1	39.9	39.6	38.8	35.3	35.3	35.3	35.2	35.2	20	
24		-	-	30.3	31.3	30.7	30.0	32.1	31.3	30.5	30.9	30.5	24	
28		-	-	-	23.2	22.8	22.1	23.9	23.4	23.0	24.3	23.9	28	
32		-	-	-	-	17.6	17.2	18.7	18.3	17.8	19.2	18.7	32	
36		-	-	-	-	-	13.5	15.1	14.6	14.2	15.5	15.1	36	
40		-	-	-	-	-	-	12.4	12.0	11.6	12.7	12.4	40	
44		-	-	-	-	-	-	-	9.9	9.6	10.7	10.3	44	
48		-	-	-	-	-	-	-	-	8.0	9.1	8.6	48	
52		-	-	-	-	-	-	-	-	-	7.7	7.4	52	
1)		39.9	31.5	24.0	19.4	15.2	11.9	11.0	9.0	7.3	7.3	5.7	1)	

		67.6 ft	71.5 ft	75.5 ft	79.4 ft	83.0 ft	86.9 ft	90.9 ft	94.5 ft	98.4 ft	102.4 ft		
ft		1,000 lb											ft
14		35.3	-	-	-	-	-	-	-	-	-	-	14
16		35.3	35.3	-	-	-	-	-	-	-	-	-	16
18		35.3	35.3	35.3	-	-	-	-	-	-	-	-	18
20		35.1	35.0	34.8	34.2	31.8	-	-	-	-	-	-	20
24		29.5	28.4	28.0	28.1	27.4	26.6	24.7	25.7	-	-	-	24
28		23.4	24.3	23.5	22.6	21.9	21.3	20.6	20.6	19.4	19.5	-	28
32		18.3	19.4	18.9	18.5	18.0	17.4	17.0	17.2	17.0	16.4	-	32
36		14.6	15.7	15.3	15.1	14.6	15.0	15.1	14.6	14.2	13.7	-	36
40		12.0	12.9	12.6	12.2	13.1	12.8	12.4	12.2	12.0	11.6	-	40
44		10.0	10.9	10.5	10.3	11.0	10.7	10.5	10.3	10.0	9.8	-	44
48		8.4	9.3	8.9	8.6	9.4	9.1	8.9	8.6	8.4	8.0	-	48
52		7.0	7.9	7.6	7.2	8.1	7.7	7.4	7.2	7.0	6.8	-	52
56		5.9	6.8	6.6	6.1	7.0	6.6	6.3	6.1	5.9	5.7	-	56
60		-	5.8	5.5	5.1	6.0	5.7	5.3	5.1	4.9	4.7	-	60
64		-	-	4.7	4.4	5.2	4.8	4.5	4.3	4.1	3.9	-	64
68		-	-	-	3.7	4.4	4.1	3.9	3.6	3.4	3.2	-	68
72		-	-	-	3.1	3.8	3.6	3.3	2.9	2.7	2.5	-	72
76		-	-	-	-	-	3.0	2.8	2.4	2.2	1.9	-	76
80		-	-	-	-	-	-	2.3	2.0	1.8	-	-	80
84		-	-	-	-	-	-	-	1.6	-	-	-	84
1)		4.6	4.9	3.7	2.9	3.3	2.4	1.8	1.3	-	-	-	1)

1) Capacities with horizontal boom

11,700 lb		14.4 ft x 21.0 ft					30°		360°		ASME B30.5	
ft	25.6 ft	29.2 ft	33.1 ft	37.1 ft	40.7 ft	44.6 ft	48.6 ft	52.5 ft	56.1 ft	60.0 ft	64.0 ft	ft
	1,000 lb											
10	46.6	48.1	49.9	50.4	50.9	51.3	35.3	35.3	35.3	35.3	-	10
12	45.1	46.3	48.2	49.6	50.1	50.1	35.3	35.3	35.3	35.3	35.3	12
14	43.4	44.9	46.5	48.0	49.0	47.5	35.3	35.3	35.3	35.3	35.3	14
16	40.6	43.0	42.9	42.9	42.8	41.5	35.3	35.3	35.3	35.3	35.3	16
18	35.8	35.5	35.3	35.3	35.3	35.3	35.3	35.3	35.3	35.3	34.6	18
20	-	29.2	30.1	30.9	30.3	29.8	31.4	30.9	30.5	31.6	30.5	20
24	-	-	21.7	22.4	22.0	21.7	23.0	22.6	22.1	23.3	23.0	24
28	-	-	-	17.3	16.9	16.4	17.8	17.3	17.1	18.0	17.8	28
32	-	-	-	-	13.4	13.1	14.2	13.9	13.5	14.5	14.2	32
36	-	-	-	-	-	10.6	11.7	11.3	11.1	12.0	11.7	36
40	-	-	-	-	-	-	9.9	9.4	9.2	10.1	9.7	40
44	-	-	-	-	-	-	-	8.0	7.8	8.5	8.3	44
48	-	-	-	-	-	-	-	-	6.5	7.4	7.2	48
52	-	-	-	-	-	-	-	-	-	6.3	6.1	52
1)	31.3	22.5	17.9	14.6	11.7	9.3	8.8	7.3	6.0	6.0	4.9	1)







ft	67.6 ft	71.5 ft	75.5 ft	79.4 ft	83.0 ft	86.9 ft	90.9 ft	94.5 ft	98.4 ft	102.4 ft	ft
	1,000 lb										
14	35.3	-	-	-	-	-	-	-	-	-	14
16	35.3	35.3	-	-	-	-	-	-	-	-	16
18	33.6	32.5	32.5	-	-	-	-	-	-	-	18
20	29.7	29.9	29.0	28.2	27.3	22.5	-	-	-	-	20
24	22.6	23.5	23.1	22.6	21.8	21.2	20.6	20.9	-	-	24
28	17.5	18.2	18.0	17.7	17.6	18.2	17.8	17.3	16.9	16.4	28
32	14.0	14.7	14.4	14.2	14.8	14.5	14.3	14.1	13.9	13.7	32
36	11.5	12.2	12.0	11.5	12.2	12.0	11.7	11.5	11.3	11.3	36
40	9.4	10.1	9.9	9.7	10.3	10.1	9.9	9.7	9.4	9.2	40
44	8.0	8.7	8.5	8.2	8.7	8.5	8.3	8.2	8.0	7.8	44
48	6.8	7.4	7.2	6.9	7.6	7.4	7.2	6.9	6.7	6.7	48
52	5.9	6.5	6.3	6.1	6.5	6.3	6.1	6.1	5.8	5.6	52
56	5.0	5.7	5.5	5.2	5.7	5.5	5.3	5.2	5.0	4.8	56
60	-	4.9	4.7	4.5	4.9	4.7	4.7	4.5	4.3	4.1	60
64	-	-	4.2	4.0	4.4	4.2	4.0	3.9	3.7	3.5	64
68	-	-	-	3.4	3.9	3.6	3.4	3.4	3.2	3.0	68
72	-	-	-	2.9	3.5	3.3	3.1	2.9	2.7	2.7	72
76	-	-	-	-	-	2.8	2.6	2.6	2.4	2.1	76
80	-	-	-	-	-	-	2.3	2.1	1.9	1.7	80
84	-	-	-	-	-	-	-	1.7	1.5	-	84
1)	4.2	4.2	3.5	2.9	3.1	2.4	2.0	1.3	-	-	1)



1) Capacities with horizontal boom

11,700 lb		7.7 ft x 21.0 ft											30°	360°	ASME B30.5
ft	25.6 ft	29.2 ft	33.1 ft	37.1 ft	40.7 ft	44.6 ft	48.6 ft	52.5 ft	56.1 ft	60.0 ft	64.0 ft	ft			
	1,000 lb														
18	15.9	15.5	16.4	16.8	16.4	16.2	17.3	17.0	16.6	17.7	17.3	18			
20	-	13.1	13.8	14.2	14.0	13.6	14.7	14.4	14.0	15.1	14.7	20			
24	-	-	10.2	10.6	10.3	10.0	11.1	10.8	10.4	11.3	11.1	24			
28	-	-	-	8.3	7.9	7.7	8.6	8.3	8.1	8.8	8.5	28			
32	-	-	-	-	6.2	5.8	6.9	6.5	6.3	7.1	6.8	32			
36	-	-	-	-	-	4.7	5.5	5.3	5.1	5.8	5.5	36			
40	-	-	-	-	-	-	4.5	4.2	4.0	4.7	4.5	40			
44	-	-	-	-	-	-	-	3.4	3.2	3.8	3.6	44			
48	-	-	-	-	-	-	-	-	2.6	3.2	3.0	48			
52	-	-	-	-	-	-	-	-	-	2.7	2.5	52			
1)	14.1	10.1	8.2	6.8	5.3	4.0	4.0	3.1	2.2	2.4	1.8	1)			

ft	67.6 ft	71.5 ft	75.5 ft	79.4 ft	83.0 ft	86.9 ft	90.9 ft	94.5 ft	98.4 ft	102.4 ft	ft
	1,000 lb										
18	17.0	17.7	16.8	-	-	-	-	-	-	-	18
20	14.4	15.1	14.9	14.3	15.0	14.3	-	-	-	-	20
24	10.8	11.5	11.2	11.0	11.5	11.3	11.0	10.7	-	-	24
28	8.3	9.0	8.8	8.5	9.0	8.8	8.6	8.5	8.3	7.9	28
32	6.6	7.2	6.9	6.7	7.4	7.2	6.9	6.7	6.5	6.4	32
36	5.3	6.0	5.5	5.5	6.0	5.8	5.5	5.3	5.3	5.1	36
40	4.2	4.9	4.7	4.5	4.9	4.7	4.5	4.5	4.2	4.0	40
44	3.4	4.0	3.8	3.6	4.0	3.8	3.8	3.6	3.4	3.3	44
48	2.8	3.2	3.0	3.0	3.5	3.2	3.0	2.8	2.8	2.6	48
52	2.3	2.7	2.5	2.3	2.9	2.7	2.5	2.3	2.3	2.1	52
56	1.7	2.4	2.2	2.0	2.4	2.2	2.0	2.0	-	-	56
60	-	1.9	1.7	-	1.9	1.7	1.6	-	-	-	60
64	-	-	-	-	1.7	-	-	-	-	-	64
1)	-	1.5	-	-	-	-	-	-	-	-	1)

1) Capacities with horizontal boom

 11,700 lb		 20.3 ft x 21.0 ft					 0°		360°		ASME B30.5	
 	25.6 ft	29.2 ft	33.1 ft	37.1 ft	40.7 ft	44.6 ft	48.6 ft	52.5 ft	56.1 ft	60.0 ft	64.0 ft	
ft	1,000 lb											ft
14	57.1	-	-	-	-	-	-	-	-	-	-	14
16	56.9	55.1	-	-	-	-	-	-	-	-	-	16
18	51.1	50.6	-	-	-	-	-	-	-	-	-	18
20	-	44.9	44.4	-	-	-	-	-	-	-	-	20
24	-	-	35.9	35.5	35.3	-	-	-	-	-	-	24
28	-	-	-	31.2	30.9	30.5	-	-	-	-	-	28
32	-	-	-	-	25.7	25.1	26.7	26.2	-	-	-	32
36	-	-	-	-	-	20.6	21.9	21.5	21.0	-	-	36
40	-	-	-	-	-	-	18.5	18.0	17.6	18.7	18.3	40
44	-	-	-	-	-	-	-	15.4	15.0	16.0	15.6	44
48	-	-	-	-	-	-	-	-	12.8	13.9	13.5	48
52	-	-	-	-	-	-	-	-	-	12.1	11.9	52
1)	39.9	34.4	30.6	27.3	22.3	18.1	16.5	13.9	11.9	11.5	9.7	1)

 	67.6 ft	71.5 ft	75.5 ft	79.4 ft	83.0 ft	86.9 ft	90.9 ft	94.5 ft	98.4 ft	102.4 ft	
ft	1,000 lb										ft
44	15.4	-	-	-	-	-	-	-	-	-	44
48	13.2	14.1	13.7	-	-	-	-	-	-	-	48
52	11.4	12.3	11.9	-	-	-	-	-	-	-	52
56	10.1	10.9	10.5	10.3	10.1	10.1	-	-	-	-	56
60	-	9.7	9.4	9.0	9.1	9.4	9.2	-	-	-	60
64	-	-	8.4	8.0	8.4	8.4	8.2	7.9	-	-	64
68	-	-	7.5	7.1	7.8	7.5	7.2	7.0	6.8	6.6	68
72	-	-	-	6.4	7.1	6.6	6.4	6.2	6.0	5.8	72
76	-	-	-	-	-	6.1	5.7	5.4	5.2	5.0	76
80	-	-	-	-	-	-	5.1	4.9	4.7	4.4	80
84	-	-	-	-	-	-	-	4.4	4.1	3.7	84
88	-	-	-	-	-	-	-	-	3.6	3.3	88
92	-	-	-	-	-	-	-	-	-	2.9	92
1)	8.4	8.4	7.1	6.2	6.2	5.3	4.4	3.7	3.1	2.4	1)

1) Capacities with horizontal boom

6,400 lb		20.3 ft x 21.0 ft										0°		360°		ASME B30.5	
		25.6 ft	29.2 ft	33.1 ft	37.1 ft	40.7 ft	44.6 ft	48.6 ft	52.5 ft	56.1 ft	60.0 ft	64.0 ft					
ft	1,000 lb											ft					
14	57.1	-	-	-	-	-	-	-	-	-	-	-	14				
16	55.1	54.1	-	-	-	-	-	-	-	-	-	-	16				
18	48.9	48.4	-	-	-	-	-	-	-	-	-	-	18				
20	-	42.9	42.4	-	-	-	-	-	-	-	-	-	20				
24	-	-	34.6	34.9	34.6	-	-	-	-	-	-	-	24				
28	-	-	-	28.5	27.8	27.4	-	-	-	-	-	-	28				
32	-	-	-	-	21.9	21.5	23.0	22.6	-	-	-	-	32				
36	-	-	-	-	-	17.3	18.8	18.4	17.9	-	-	-	36				
40	-	-	-	-	-	-	15.7	15.2	14.9	16.1	15.7	-	40				
44	-	-	-	-	-	-	-	12.9	12.5	13.6	13.2	-	44				
48	-	-	-	-	-	-	-	-	10.6	11.7	11.3	-	48				
52	-	-	-	-	-	-	-	-	-	10.1	9.9	-	52				
1)	39.9	34.4	29.1	23.6	19.0	15.2	14.1	11.7	9.9	9.5	7.9	-	1)				







		67.6 ft	71.5 ft	75.5 ft	79.4 ft	83.0 ft	86.9 ft	90.9 ft	94.5 ft	98.4 ft	102.4 ft		
ft	1,000 lb											ft	
44	12.9	-	-	-	-	-	-	-	-	-	-	-	44
48	11.1	11.7	11.5	-	-	-	-	-	-	-	-	-	48
52	9.5	10.3	9.9	-	-	-	-	-	-	-	-	-	52
56	8.3	9.0	8.8	8.3	9.2	8.8	-	-	-	-	-	-	56
60	-	8.0	7.7	7.2	8.0	7.7	7.5	-	-	-	-	-	60
64	-	-	6.7	6.3	7.2	6.7	6.5	6.3	-	-	-	-	64
68	-	-	5.9	5.5	6.4	5.9	5.7	5.5	5.2	5.0	-	-	68
72	-	-	-	4.9	5.5	5.3	4.9	4.7	4.4	4.2	-	-	72
76	-	-	-	-	-	4.6	4.3	4.1	3.9	3.6	-	-	76
80	-	-	-	-	-	-	3.8	3.6	3.4	3.0	-	-	80
84	-	-	-	-	-	-	-	3.0	2.8	2.6	-	-	84
88	-	-	-	-	-	-	-	-	2.3	2.1	-	-	88
92	-	-	-	-	-	-	-	-	-	1.8	-	-	92
1)	6.6	6.6	5.5	4.6	4.9	4.0	3.3	2.6	2.0	1.5	-	-	1)



1) Capacities with horizontal boom

11,700 lb		14.4 ft x 21.0 ft										0°		360°		ASME B30.5	
		25.6 ft	29.2 ft	33.1 ft	37.1 ft	40.7 ft	44.6 ft	48.6 ft	52.5 ft	56.1 ft	60.0 ft	64.0 ft					
ft	1,000 lb											ft					
14	55.0	-	-	-	-	-	-	-	-	-	-	-	14				
16	45.3	44.4	-	-	-	-	-	-	-	-	-	-	16				
18	35.9	35.0	-	-	-	-	-	-	-	-	-	-	18				
20	-	29.0	29.8	-	-	-	-	-	-	-	-	-	20				
24	-	-	21.7	22.4	21.7	-	-	-	-	-	-	-	24				
28	-	-	-	17.1	16.7	16.2	-	-	-	-	-	-	28				
32	-	-	-	-	13.3	12.9	14.1	13.8	-	-	-	-	32				
36	-	-	-	-	-	10.6	11.7	11.3	10.9	-	-	-	36				
40	-	-	-	-	-	-	9.7	9.4	9.0	9.9	9.7	-	40				
44	-	-	-	-	-	-	-	8.0	7.6	8.5	8.2	-	44				
48	-	-	-	-	-	-	-	-	6.5	7.4	6.9	-	48				
52	-	-	-	-	-	-	-	-	-	6.3	6.1	-	52				
1)	30.4	22.0	17.4	14.3	11.5	9.3	8.8	7.3	6.0	6.0	4.9	1)					

		67.6 ft	71.5 ft	75.5 ft	79.4 ft	83.0 ft	86.9 ft	90.9 ft	94.5 ft	98.4 ft	102.4 ft		
ft	1,000 lb											ft	
44	7.8	-	-	-	-	-	-	-	-	-	-	-	44
48	6.7	7.4	7.2	-	-	-	-	-	-	-	-	-	48
52	5.8	6.5	6.1	-	-	-	-	-	-	-	-	-	52
56	5.0	5.7	5.3	5.0	5.7	5.5	-	-	-	-	-	-	56
60	-	4.9	4.7	4.5	4.9	4.7	4.5	-	-	-	-	-	60
64	-	-	4.2	4.0	4.4	4.2	4.0	3.7	-	-	-	-	64
68	-	-	3.6	3.4	3.9	3.6	3.4	3.2	3.1	3.0	-	-	68
72	-	-	-	2.9	3.3	3.1	3.1	2.9	2.7	2.4	-	-	72
76	-	-	-	-	-	2.8	2.6	2.4	2.2	2.1	-	-	76
80	-	-	-	-	-	-	2.3	2.1	1.9	1.7	-	-	80
84	-	-	-	-	-	-	-	1.7	1.5	-	-	-	84
1)	4.2	4.2	3.5	2.9	3.1	2.4	2.0	1.3	-	-	-	1)	

1) Capacities with horizontal boom

 11,700 lb		 7.7 ft x 21.0 ft						 0°		360°		ASME B30.5	
 	25.6 ft	29.2 ft	33.1 ft	37.1 ft	40.7 ft	44.6 ft	48.6 ft	52.5 ft	56.1 ft	60.0 ft	64.0 ft		
ft	1,000 lb											ft	
18	15.9	15.3	-	-	-	-	-	-	-	-	-	18	
20	-	12.9	13.6	-	-	-	-	-	-	-	-	20	
24	-	-	10.1	10.5	10.1	-	-	-	-	-	-	24	
28	-	-	-	8.1	7.7	7.5	-	-	-	-	-	28	
32	-	-	-	-	6.1	5.8	6.7	6.5	-	-	-	32	
36	-	-	-	-	-	4.7	5.5	5.1	4.9	-	-	36	
40	-	-	-	-	-	-	4.5	4.2	3.9	4.7	4.3	40	
44	-	-	-	-	-	-	-	3.4	3.1	3.8	3.6	44	
48	-	-	-	-	-	-	-	-	2.6	3.2	3.0	48	
52	-	-	-	-	-	-	-	-	-	2.7	2.5	52	
1)	13.7	9.9	8.2	6.8	5.3	4.0	4.0	3.1	2.2	2.4	1.8	1)	

 	67.6 ft	71.5 ft	75.5 ft	79.4 ft	83.0 ft	86.9 ft	90.9 ft	94.5 ft	98.4 ft	102.4 ft	
ft	1,000 lb										ft
44	3.3	-	-	-	-	-	-	-	-	-	44
48	2.8	3.2	3.0	-	-	-	-	-	-	-	48
52	2.3	2.7	2.5	-	-	-	-	-	-	-	52
56	1.7	2.2	2.0	1.7	2.4	2.2	-	-	-	-	56
60	-	1.9	1.6	-	1.9	1.7	-	-	-	-	60
64	-	-	-	-	1.5	-	-	-	-	-	64
1)	-	1.3	-	-	-	-	-	-	-	-	1)

1) Capacities with horizontal boom

11,700 lb		20.3 ft x 21.0 ft										-20°		360°		ASME B30.5	
ft		25.6 ft	29.2 ft	33.1 ft	37.1 ft	40.7 ft	44.6 ft	48.6 ft	52.5 ft	56.1 ft	60.0 ft	64.0 ft	ft				
ft		1,000 lb										ft					
18	51.1	-	-	-	-	-	-	-	-	-	-	-	18				
20	-	44.7	-	-	-	-	-	-	-	-	-	-	20				
28	-	-	-	31.2	-	-	-	-	-	-	-	-	28				
32	-	-	-	-	25.6	-	-	-	-	-	-	-	32				
36	-	-	-	-	-	20.4	-	-	-	-	-	-	36				
40	-	-	-	-	-	-	18.5	-	-	-	-	-	40				
44	-	-	-	-	-	-	-	15.4	-	-	-	-	44				
48	-	-	-	-	-	-	-	-	12.8	13.9	-	-	48				
52	-	-	-	-	-	-	-	-	-	12.1	-	-	52				
1)	39.9	34.4	-	27.6	22.5	18.1	16.8	14.1	11.9	11.5	-	-	1)				

ft		67.6 ft	71.5 ft	75.5 ft	79.4 ft	83.0 ft	86.9 ft	90.9 ft	94.5 ft	98.4 ft	102.4 ft	ft	
ft		1,000 lb										ft	
56	10.1	-	-	-	-	-	-	-	-	-	-	-	56
60	-	9.7	-	-	-	-	-	-	-	-	-	-	60
64	-	-	8.3	-	-	-	-	-	-	-	-	-	64
68	-	-	7.5	7.0	-	-	-	-	-	-	-	-	68
72	-	-	-	6.2	7.1	-	-	-	-	-	-	-	72
76	-	-	-	-	-	5.9	5.7	-	-	-	-	-	76
80	-	-	-	-	-	-	5.1	4.7	-	-	-	-	80
84	-	-	-	-	-	-	-	4.3	3.9	-	-	-	84
88	-	-	-	-	-	-	-	-	3.6	3.2	-	-	88
92	-	-	-	-	-	-	-	-	-	2.9	-	-	92
1)	8.6	8.4	7.1	6.2	6.2	5.3	4.4	3.7	3.1	2.4	-	-	1)

1) Capacities with horizontal boom

6,400 lb		20.3 ft x 21.0 ft										- 20°		360°		ASME B30.5	
		25.6 ft	29.2 ft	33.1 ft	37.1 ft	40.7 ft	44.6 ft	48.6 ft	52.5 ft	56.1 ft	60.0 ft	64.0 ft					
ft		1,000 lb										ft					
18	48.7	-	-	-	-	-	-	-	-	-	-	-	18				
20	-	42.7	-	-	-	-	-	-	-	-	-	-	20				
28	-	-	-	-	28.3	-	-	-	-	-	-	-	28				
32	-	-	-	-	-	21.9	-	-	-	-	-	-	32				
36	-	-	-	-	-	-	17.3	-	-	-	-	-	36				
40	-	-	-	-	-	-	-	15.7	-	-	-	-	40				
44	-	-	-	-	-	-	-	-	12.9	-	-	-	44				
48	-	-	-	-	-	-	-	-	-	10.6	11.7	-	48				
52	-	-	-	-	-	-	-	-	-	-	10.1	-	52				
1)	39.9	34.4	-	-	23.8	19.2	15.4	14.1	11.7	9.9	9.5	-	1)				

		67.6 ft	71.5 ft	75.5 ft	79.4 ft	83.0 ft	86.9 ft	90.9 ft	94.5 ft	98.4 ft	102.4 ft		
ft		1,000 lb										ft	
56	8.1	-	-	-	-	-	-	-	-	-	-	-	56
60	-	7.9	-	-	-	-	-	-	-	-	-	-	60
64	-	-	6.6	-	-	-	-	-	-	-	-	-	64
68	-	-	5.9	5.5	-	-	-	-	-	-	-	-	68
72	-	-	-	4.9	5.5	-	-	-	-	-	-	-	72
76	-	-	-	-	-	4.6	4.3	-	-	-	-	-	76
80	-	-	-	-	-	-	3.8	3.4	-	-	-	-	80
84	-	-	-	-	-	-	-	3.0	2.7	-	-	-	84
88	-	-	-	-	-	-	-	-	2.3	2.1	-	-	88
92	-	-	-	-	-	-	-	-	-	1.8	-	-	92
1)	6.8	6.8	5.5	4.6	4.9	4.0	3.3	2.6	2.0	1.5	-	-	1)

0 lb		20.3 ft x 21.0 ft										- 20°		360°		ASME B30.5	
		25.6 ft	29.2 ft	33.1 ft	37.1 ft	40.7 ft	44.6 ft	48.6 ft	52.5 ft	56.1 ft	60.0 ft	64.0 ft					
ft		1,000 lb										ft					
18	46.0	-	-	-	-	-	-	-	-	-	-	-	18				
20	-	40.1	-	-	-	-	-	-	-	-	-	-	20				
28	-	-	-	-	23.0	-	-	-	-	-	-	-	28				
32	-	-	-	-	-	17.4	-	-	-	-	-	-	32				
36	-	-	-	-	-	-	13.3	-	-	-	-	-	36				
40	-	-	-	-	-	-	-	12.2	-	-	-	-	40				
44	-	-	-	-	-	-	-	-	9.8	-	-	-	44				
48	-	-	-	-	-	-	-	-	-	7.8	8.9	-	48				
52	-	-	-	-	-	-	-	-	-	-	7.7	-	52				
1)	39.9	31.1	-	-	19.2	15.0	11.7	11.0	8.8	7.3	7.1	-	1)				

		67.6 ft	71.5 ft	75.5 ft	79.4 ft	83.0 ft	86.9 ft	90.9 ft	94.5 ft	98.4 ft	102.4 ft		
ft		1,000 lb										ft	
56	5.7	-	-	-	-	-	-	-	-	-	-	-	56
60	-	5.8	-	-	-	-	-	-	-	-	-	-	60
64	-	-	4.6	-	-	-	-	-	-	-	-	-	64
68	-	-	3.9	3.6	-	-	-	-	-	-	-	-	68
72	-	-	-	3.1	3.8	-	-	-	-	-	-	-	72
76	-	-	-	-	-	2.8	2.6	-	-	-	-	-	76
80	-	-	-	-	-	-	-	2.1	1.9	-	-	-	80
84	-	-	-	-	-	-	-	-	1.6	-	-	-	84
1)	4.6	4.9	3.7	2.9	3.1	2.4	1.8	1.3	-	-	-	-	1)

1) Capacities with horizontal boom

11,700 lb		14.4 ft x 21.0 ft										- 20°	360°	ASME B30.5
		25.6 ft	29.2 ft	33.1 ft	37.1 ft	40.7 ft	44.6 ft	48.6 ft	52.5 ft	56.1 ft	60.0 ft	64.0 ft		
ft	1,000 lb											ft		
18	35.7	-	-	-	-	-	-	-	-	-	-	-	18	
20	-	28.6	-	-	-	-	-	-	-	-	-	-	20	
28	-	-	-	17.1	-	-	-	-	-	-	-	-	28	
32	-	-	-	-	13.3	-	-	-	-	-	-	-	32	
36	-	-	-	-	-	10.4	-	-	-	-	-	-	36	
40	-	-	-	-	-	-	9.7	-	-	-	-	-	40	
44	-	-	-	-	-	-	-	7.8	-	-	-	-	44	
48	-	-	-	-	-	-	-	-	6.5	7.2	-	-	48	
52	-	-	-	-	-	-	-	-	-	6.3	-	-	52	
1)	30.9	22.3	-	14.6	11.7	9.3	8.8	7.3	6.0	6.0	-	-	1)	

		67.6 ft	71.5 ft	75.5 ft	79.4 ft	83.0 ft	86.9 ft	90.9 ft	94.5 ft	98.4 ft	102.4 ft		
ft	1,000 lb											ft	
56	5.0	-	-	-	-	-	-	-	-	-	-	-	56
60	-	4.9	-	-	-	-	-	-	-	-	-	-	60
64	-	-	4.0	-	-	-	-	-	-	-	-	-	64
68	-	-	3.6	3.4	-	-	-	-	-	-	-	-	68
72	-	-	-	2.9	3.3	-	-	-	-	-	-	-	72
76	-	-	-	-	-	2.8	2.6	-	-	-	-	-	76
80	-	-	-	-	-	-	2.3	2.0	-	-	-	-	80
84	-	-	-	-	-	-	-	1.6	1.4	-	-	-	84
1)	4.2	4.2	3.5	2.9	3.1	2.4	2.0	1.3	-	-	-	-	1)

11,700 lb		7.7 ft x 21.0 ft										- 20°	360°	ASME B30.5
		25.6 ft	29.2 ft	33.1 ft	37.1 ft	40.7 ft	44.6 ft	48.6 ft	52.5 ft	56.1 ft	60.0 ft	64.0 ft		
ft	1,000 lb											ft		
18	15.7	-	-	-	-	-	-	-	-	-	-	-	18	
20	-	12.7	-	-	-	-	-	-	-	-	-	-	20	
28	-	-	-	8.1	-	-	-	-	-	-	-	-	28	
32	-	-	-	-	6.1	-	-	-	-	-	-	-	32	
36	-	-	-	-	-	4.4	-	-	-	-	-	-	36	
40	-	-	-	-	-	-	4.5	-	-	-	-	-	40	
44	-	-	-	-	-	-	-	3.3	-	-	-	-	44	
48	-	-	-	-	-	-	-	-	2.4	3.0	-	-	48	
52	-	-	-	-	-	-	-	-	-	2.7	-	-	52	
1)	13.9	9.9	-	6.8	5.3	4.0	4.0	3.1	2.2	2.4	-	-	1)	

		67.6 ft	71.5 ft	75.5 ft	79.4 ft	83.0 ft	86.9 ft	90.9 ft	94.5 ft	98.4 ft	102.4 ft		
ft	1,000 lb											ft	
60	-	1.9	-	-	-	-	-	-	-	-	-	-	60
1)	-	1.3	-	-	-	-	-	-	-	-	-	-	1)

1) Capacities with horizontal boom

11,700 lb 0°* 30° ASME B30.5					
ft	25.6 ft	33.1 ft	40.7 ft	44.6 ft	1,000 lb
12	31.7	31.1	30.7	30.5	
14	27.8	27.4	26.9	26.3	
16	24.6	24.0	23.4	22.2	
18	21.2	20.4	19.9	19.0	
20	-	17.0	16.3	16.1	
24	-	12.3	11.6	11.6	
28	-	-	8.7	8.5	
32	-	-	6.5	6.4	
36	-	-	-	4.9	
1)	18.7	9.7	5.5	4.0	

11,700 lb 0°* 0° ASME B30.5					
ft	25.6 ft	33.1 ft	40.7 ft	44.6 ft	1,000 lb
16	24.4	-	-	-	
18	21.2	-	-	-	
20	-	16.7	-	-	
24	-	12.0	11.4	-	
28	-	-	8.5	8.3	
32	-	-	6.5	6.3	
36	-	-	-	4.7	
1)	18.1	9.5	5.3	4.0	

11,700 lb 180°** 30° ASME B30.5					
ft	25.6 ft	33.1 ft	40.7 ft	44.6 ft	1,000 lb
12	23.0	22.3	21.9	21.9	
14	20.0	19.3	18.9	18.8	
16	17.5	16.8	16.5	16.3	
18	15.3	14.8	14.4	14.2	
20	-	13.0	12.8	12.5	
24	-	10.3	9.9	9.8	
28	-	-	7.9	7.7	
32	-	-	6.1	6.1	
36	-	-	-	4.7	
1)	14.1	8.6	5.1	4.0	

11,700 lb 180°** 0° ASME B30.5					
ft	25.6 ft	33.1 ft	40.7 ft	44.6 ft	1,000 lb
16	17.2	-	-	-	
18	15.3	-	-	-	
20	-	12.8	-	-	
24	-	10.1	9.7	-	
28	-	-	7.7	7.5	
32	-	-	6.1	5.8	
36	-	-	-	4.7	
1)	13.7	8.4	5.1	3.7	

11,700 lb 360° 30° ASME B30.5					
ft	25.6 ft	33.1 ft	40.7 ft	44.6 ft	1,000 lb
18	11.3	10.8	10.4	10.2	
20	-	9.3	8.8	8.6	
24	-	6.7	6.3	6.3	
28	-	-	4.6	4.4	
32	-	-	3.1	2.9	
36	-	-	-	1.8	
1)	10.1	5.1	2.4	1.3	

11,700 lb 360° 0° ASME B30.5					
ft	25.6 ft	33.1 ft	40.7 ft	44.6 ft	1,000 lb
18	11.3	-	-	-	
20	-	9.0	-	-	
24	-	6.5	6.1	-	
28	-	-	4.4	4.1	
32	-	-	3.0	2.9	
36	-	-	-	1.8	
1)	9.9	5.1	2.2	-	

1) Capacities with horizontal boom * over rear ** over front

Notes to Lifting Capacity

Ratings are in compliance with ASME B30.5. Lifting capacities do not exceed 85 % of tipping load.

Consult operation manual for further details.

Note: Data published herein is intended as a guide only and shall not be construed to warrant applicability for lifting purposes. Crane operation is subject to the computer charts and operation manual both supplied with the crane.

Runner and cross bar

max.
33,000 lb

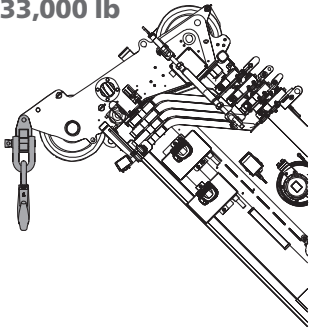

max. 55,100 lb

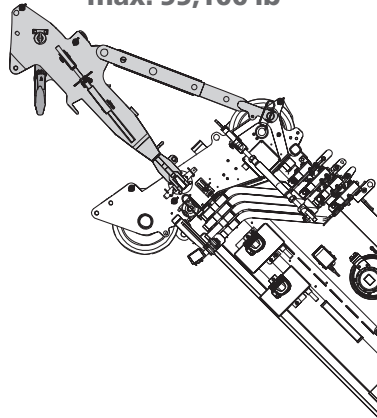

max. 55,100 lb

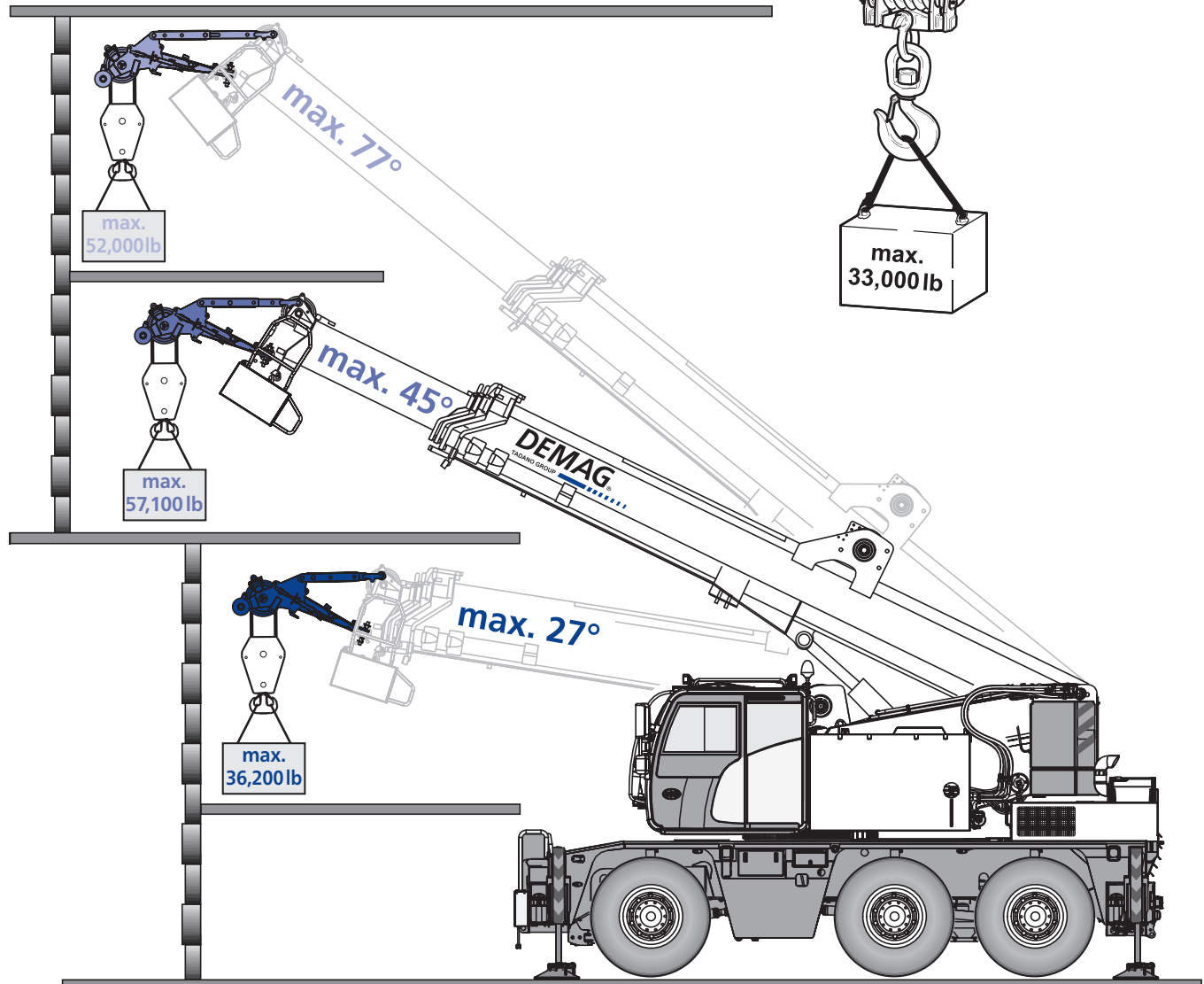
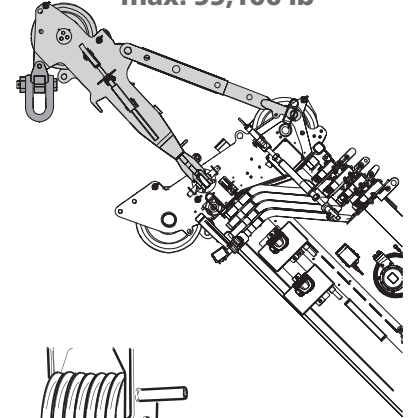

Basic machine

Equipment carrier

Engine 260-5	Mercedes-Benz OM936LA; Diesel engine; 260 kW / 2200 1/min (348 HP), torque 1450 Nm / 1200-1600 1/min; The engine complies with EU Stage V / Tier 4F; Exhaust system complete stainless steel with SCR catalyzer.
Fuel tank	Fuel tank 79 gallons Diesel (no RME / biodiesel); 11 gallons AdBlue tank.
Transmission Allison	Allison automated gearbox with torque converter, 6 forward speeds and 1 reverse; 2-stage transfer case with switchable off-road gear and switchable longitudinal lock.
Axles 6 x 4 x 6	6 x 4 x 6; 3 axles, axles 1 and 3 are driven and equipped with selectable transverse lock; All axles steered.
Suspension	Hydropneumatic suspension with axle load compensation; Hydraulically lockable; Manual or automatic levelling alternatively.
Steering	Dual circuit hydro semiblock steering with emergency steering pump; Active rear axle steering.
Brakes	Pneumatic dual circuit service brake with antilock system, acting on all wheels; Disk brakes; Additional decompression brake; Spring-loaded parking brake.
Tire size 445/65 R22.5 (18.00 R22.5)	Tire size 445/65 R22.5 (18.00 R22.5); Steel rim 14-22.5.
Drive lights	Including low beam, upper beam, daytime running lights.
Outriggers	H-4-Point design; Vertical and horizontal movement fully hydraulic; Manual or automatic levelling alternatively; 3 outrigger bases of 7.7 ft, 14.4 ft and 20.3 ft.
Outrigger pads 020 PA	4 round outrigger pads A = 0.66 ft ² with transport position at vertical cylinder; Polyamide.
Pneumatic tire filling plug	Pneumatic tire filling plug for self-filling of the wheels.
Contour safety marking	Continuous reflective strips on the sides of the chassis and in the back.

Equipment superstructure

Telescopic boom HA31	25.6 ft - 102.4 ft; Fully hydraulic telescoping system; Attachments for all equipment and extensions; 5 sheaves integrated in boom head for max. capacity of 88,200 lb.
Boom luffing	Single luffing cylinder with automatic lowering brake valve.
Rotary drive	Single slewing gear unit with spring-loaded multi-disc brake.
H1	Hoist with spring-loaded multi-disc brake; Resolver (hoist rotation indicator); Incl. hoist monitoring.
Counterweight 11,700 lb	11,700 lb, 3 pieces.
Control system	Enabling 4 simultaneous working movements; Electric pilot controls via 2 two-axis joysticks; Different control modes selectable for hydraulic circuits.
Operator aids	IC-1, with Integrated load moment indicator acc. EN13000; Color display; Displaying of current operating conditions, load charts, fault indicator; Signal lights indicating LMI-load; Crane data logger.
Outrigger basis monitoring	Surveillance of each outrigger beam for detection of horizontal stroke; Warning in case of anomaly in crane cabin (Attention: There is no automatic linkage with the LMI-system).
Outrigger load indicator	The outrigger load is indicated in the crane cabin and the outrigger control box.
Working range limiter	Displaying and programmability of the work range limits by IC-1.
Hook height indication	Displaying and programmability of the hook height H1 by IC-1.
Cab 875	Type 2.87 ft; Steering wheel height and tilt adjustable; Seat heating; Tinted glass; Power mirrors with heater; Handrails; Pull-down sun visor and light curtains; Radio; Seat heating.
Heating engine-independent	Engine-independent warm water heating with 5 kW heating power; With timer.
Aircondition	Aircondition with 7 kW rated cooling capacity.
Tachograph	Display of the speed and record according to country-specific regulations.
Electronic immobilizer system	Prevents uncontrolled carrier mobilization; Incl. 5 ignition keys.
Anemometer	Disconnectable and usable in HA and HAV configuration.

Additional equipment

Carrier

Engine 260-3; ECE R96	Mercedes-Benz OM936LA; Diesel engine; 260 kW / 2200 1/min (348 HP), torque 1400 Nm / 1200-1600 1/min; The engine complies with ECE R96 (equivalent to former regulation EU Stage III A / Tier 3); Exhaust system complete stainless steel incl. spark arrester.
Axles 6 x 6 x 6	6 x 6 x 6; Axles 1 and 3 permanently driven; Axle 2 connectable with longitudinal lock; All 3 axles equipped with shiftable transverse lock; All 3 axles steered.
CombiBox tail	Storage box for crane equipment at carrier tail.
Hook storage	Storage for single line hook (5-0-16) at carrier front.
Timber storage front	Storage for 20 x squared timber 10 x 10 x 3.3 ft at carrier front incl. lashing for secure stowage.

Superstructure

2. hoist (H2)	2. hoist; Spring-loaded multi-disc brake; Resolver (hoist rotation indicator); Incl. quick couplings; Displaying and programmability of the hook height H2 by IC-1.
Load supervision camera	Camera mounted on main boom head to supervise the hook block and load from above; Incl. boom head light on boom head.

Handling

Remote control	Control of superstructure operations via wireless remote control.
IC-1 Plus incl. Flex Base	Smart crane control system for main boom and runner configuration enabling higher lifting capacities especially over outriggers. Enables safe use of the full capacity of the crane even in asymmetric outrigger configurations. Flexible and independent outrigger positioning possible. Capacity precalculation for +/- 30° slewing angle and radius area. In-cab lift simulation.
IC-1 Remote	IC-1 Remote, Demag telematic system.

Extensions

HAV 23.0 ft	23.3 ft; Swing-away jib, manual offset 30°; 1-sheaved head; Incl. transport storage.
HAV 42.7 ft	42.7 ft; Double folding swing-away jib, manual offset 30°; 1-sheaved head; Incl. transport storage; Includes HAV 23.0 ft.
MS (runner)	4.3 ft; Variable assembly jib (runner) with manual offset; 3 sheaves; Max. capacity 57,100 lb.
Hook traverse 55,100 lb	For runner, installation in sheave axis; Incl. hook; Note: sheave axis needs to be removed.
Boom head traverse 55,100 lb	For runner, installation in front of sheave axis; Incl. shackle.
Boom head traverse 33,000 lb	Boom head traverse for main boom head or runner; Incl. shackle and hook.

Hook Blocks

Hook block 50-5-16-D	50-5-16-D (904 lb); Hook block with ramshorn hook; With white red signal stripes.
Hook block 32-3-16-D	32-3-16-D (772 lb); Hook block with ramshorn hook; With white red signal stripes.
Hook block 16-1-16-E	16-1-16-E (496 lb); Hook block with single hook; With white red signal stripes.
Hook 5-0-16-E	5-0-16-E (287 lb); Single hook; Red.

Further additional equipment on request!

Weight data may deviate from posted values based on road / travel configuration, equipment configuration, and component weight tolerances.

A large rectangular area with horizontal lines, intended for taking notes.

A large rectangular area with horizontal lines, intended for taking notes.

September 2020. Product specifications and prices are subject to change without notice or obligation. The photographs and/or drawings in this document are for illustrative purposes only. Refer to the appropriate Operator's Manual for instructions on the proper use of this equipment. Failure to follow the corresponding Operator's Manual when using our equipment or to otherwise act responsibly may result in serious injury or death. The only warranty applicable to our equipment is the standard written warranty applicable to the particular product and sale and Tadano makes no other warranty, express or implied. All rights reserved. Products and services listed may be trademarks, service marks or trade-names of Tadano Ltd.

© Tadano Demag GmbH 2020. Tadano and Demag are trademarks of or licensed by Tadano Ltd. or its subsidiaries.



Tadano Demag GmbH
Europa Allee 2
66482 Zweibrücken
Germany
T +49 6332 830

info.demag@tadano.com
www.demagmobilecranes.com



Tadano Ltd. (International Division)
4-12, Kamezawa 2-chome
Sumida-ku Tokyo 130-0014, Japan
E info@tadano.com T 81-3-3621-7750
www.tadano.com